

FAX UNIT
(Machine Code: B502)
SERVICE MANUAL

TABLE OF CONTENTS

1. INSTALLATION.....	1-1
1.1 FAX UNIT	1-1
1.2 FAX UNIT OPTIONS	1-8
1.2.1 G3 INTERFACE UNIT	1-8
1.2.2 ISDN OPTION.....	1-14
1.2.3 EXPANSION MEMORY	1-19
1.2.4 FAX FUNCTION UPGRADE KIT	1-20
1.2.5 HANDSET.....	1-21
2. REPLACEMENT AND ADJUSTMENT.....	2-1
2.1 NOTES FOR FCU BOARD REPLACEMENT	2-1
3. TROUBLESHOOTING.....	3-1
3.1 ERROR CODES	3-1
3.2 ERROR CODES FOR THE ISDN OPTION	3-9
3.2.1 D-CHANNEL LAYER MANAGEMENT.....	3-10
3.2.2 D-CHANNEL, LAYER 1	3-10
3.2.3 D-CHANNEL LINK LAYER	3-10
3.2.4 D-CHANNEL NETWORK LAYER	3-11
3.2.5 B-CHANNEL LINK LAYER.....	3-11
3.2.6 B-CHANNEL NETWORK LAYER	3-12
3.2.7 TRANSPORT LAYER	3-12
3.2.8 SESSION LAYER	3-13
3.2.9 DOCUMENT LAYER	3-14
3.2.10 PRESENTATION LAYER	3-14
3.3 FAX SC CODES	3-15
3.3.1 OVERVIEW.....	3-15
3.3.2 SC1201	3-15
3.3.3 SC1207	3-15
3.3.4 FAX SC CODE TABLE	3-16
3.4 ISDN TEST FUNCTION.....	3-17
3.4.1 LEDS	3-17
3.4.2 BACK-TO-BACK TEST.....	3-18
4. SERVICE TABLES.....	4-1
4.1 SERVICE PROGRAM MODE	4-1
4.1.1 SERVICE PROGRAM MODE OPERATION.....	4-1
Entering and Exiting SP Mode	4-1
SP Mode Button Summary.....	4-2
Switching Between SP Mode and Copy Mode for Test Printing.....	4-3
Selecting the Program Number	4-3
4.1.2 SERVICE PROGRAM MODE TABLES	4-4
SP1-XXX (Bit Switches)	4-4
SP2-XXX (RAM Data)	4-4
SP3-XXX (Tel Line Settings).....	4-5

SP4-XXX (ROM Versions)	4-6
SP5-XXX (Initializing)	4-6
SP6-XXX (Reports)	4-6
SP7-XXX (Test Modes)	4-8
4.2 BIT SWITCHES	4-9
4.2.1 SYSTEM SWITCHES	4-9
4.2.2 SCANNER SWITCHES	4-21
4.2.3 PRINTER SWITCHES	4-25
4.2.4 COMMUNICATION SWITCHES	4-31
4.2.5 G3 SWITCHES	4-40
4.2.6 G3-2 SWITCHES	4-47
4.2.7 G4 INTERNAL SWITCHES	4-53
4.2.8 G4 PARAMETER SWITCHES	4-60
4.3 NCU PARAMETERS	4-63
4.4 DEDICATED TRANSMISSION PARAMETERS	4-72
4.4.1 PROGRAMMING PROCEDURE	4-72
4.4.2 PARAMETERS	4-73
4.5 SERVICE RAM ADDRESSES	4-77
5. DETAILED SECTION DESCRIPTIONS.....	5-1
5.1 OVERVIEW	5-1
5.2 BOARDS.....	5-2
5.2.1 FCU	5-2
5.2.2 MBU	5-3
5.2.3 NCU (US).....	5-4
5.2.4 NCU (EUROPE/ASIA)	5-5
5.2.5 NCU (OPTIONAL G3 INTERFACE: EUROPE/ASIA)	5-6
5.2.6 SG3 BOARD	5-7
5.2.7 SIG4 BOARD	5-8
5.3 VIDEO DATA PATH.....	5-9
5.3.1 TRANSMISSION.....	5-9
Memory Transmission and Parallel Memory Transmission	5-10
Immediate Transmission	5-10
JBIG Transmission	5-10
I-G3 (ISDN G3) Transmission	5-10
Adjustments	5-10
5.3.2 RECEPTION.....	5-11
5.4 FAX COMMUNICATION FEATURES.....	5-12
5.4.1 PERSONAL/INFORMATION/TRANSFER BOXES.....	5-12
Personal Box (Confidential Box)	5-12
Transfer Box.....	5-13
Information Box (Polling Tx).....	5-14
5.4.2 MULTI-PORT	5-15
5.4.3 DOCUMENT SERVER	5-16
5.4.4 LAN FAX DRIVER	5-17
Regular Transmission	5-18
Print and Transmission	5-18
Using the Document Server	5-18

SPECIFICATIONS.....Spec-1
1. GENERAL SPECIFICATIONS..... Spec-1
2. CAPABILITIES OF PROGRAMMABLE ITEMS Spec-3
3. MACHINE CONFIGURATION Spec-4

1. INSTALLATION

1.1 FAX UNIT

⚠ CAUTION

Before installing this fax unit,

- 1) Print out all data in the printer buffer if there is an optional printer installed.
- 2) Turn off the main switch and disconnect the power cord and the network cable.

1. Remove the rear cover [A] (⚙ x 2).
2. Remove the connector cover [B].
3. When installing *G3 Interface Unit Type 1232*, cut away the right connector shield [C] and file the edges smooth.
4. When installing *ISDN Option Type 1232*, cut away the left connector shield [D] and file the edges smooth.

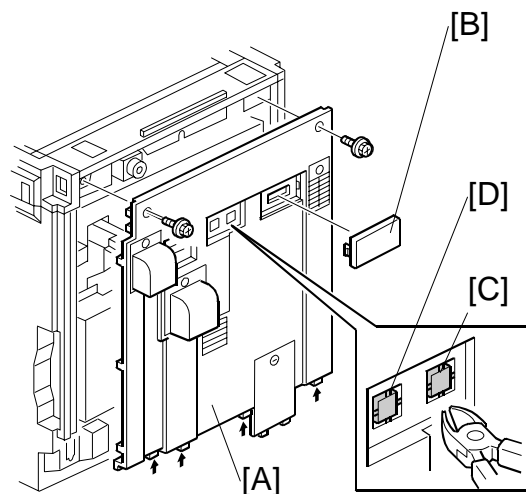

B502I003.WMF

5. Install the jack cover [A].

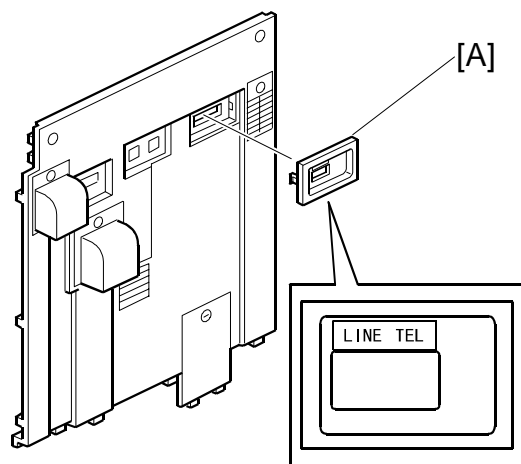

B502I013.WMF

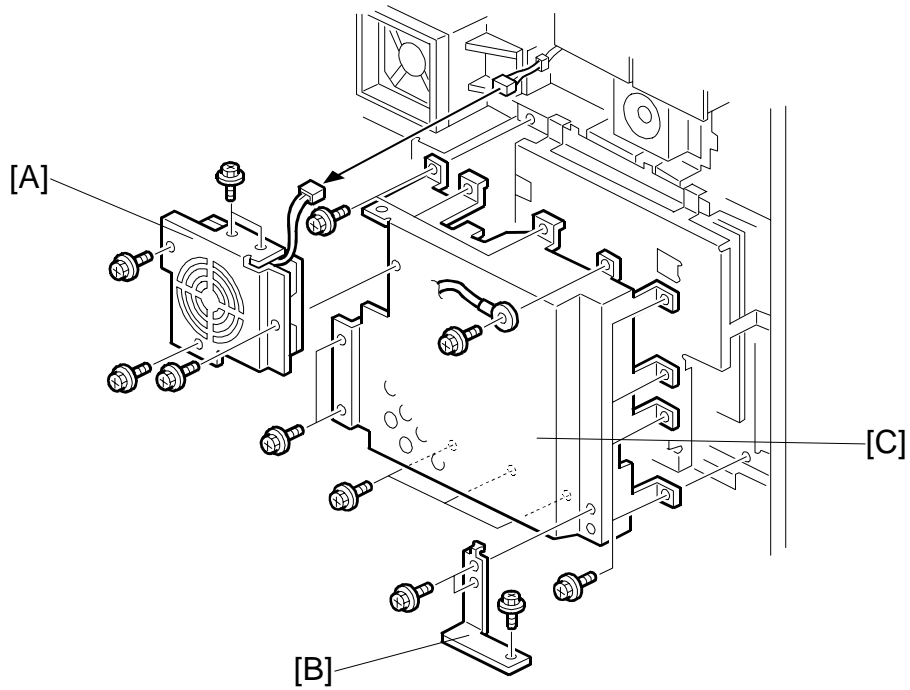

B5021014.WMF

6. Remove the fan with the bracket [A] (⌀ x 5, 𐀀 x 1).
7. Remove the ground bracket [B] (⌀ x 3).
8. Remove the BCU cover [C] (⌀ x 13).

U.S. VERSION

NON-U.S. VERSION

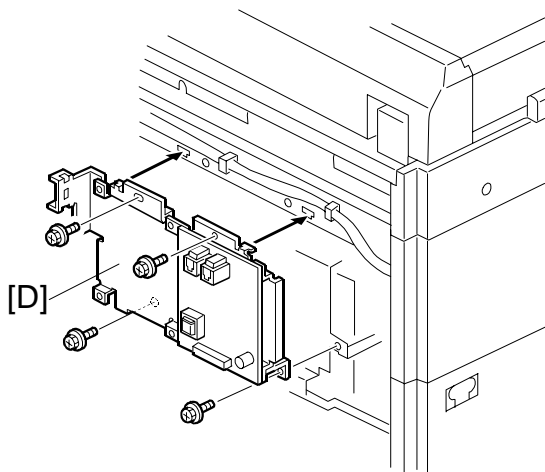

B5021104.WMF

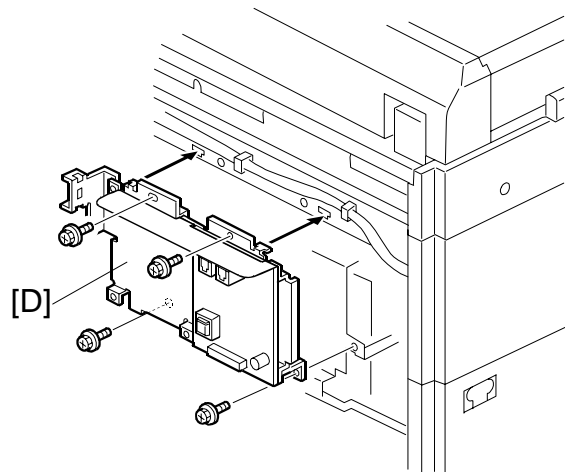

B5021112.WMF

9. Attach the NCU [D] (⌀ x 4).

10. Attach the speaker [A] (⚙️ x 2).

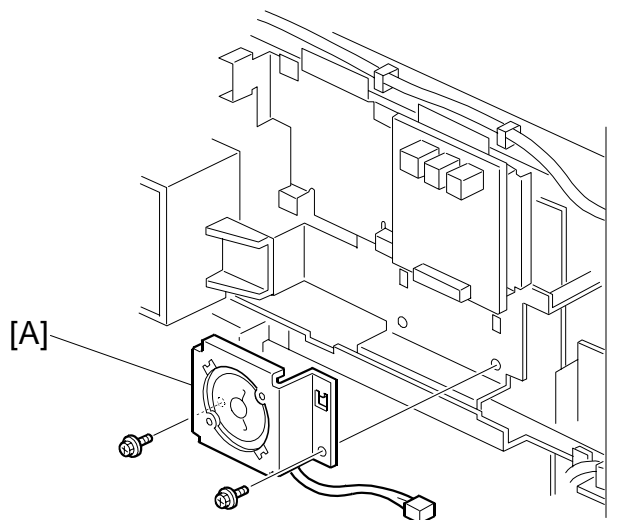

B5021012.WMF

U.S. VERSION

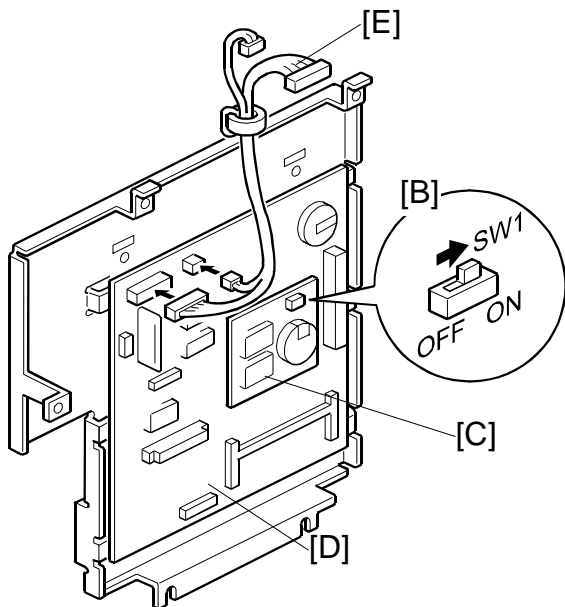

B5021011.WMF

NON-U.S. VERSION

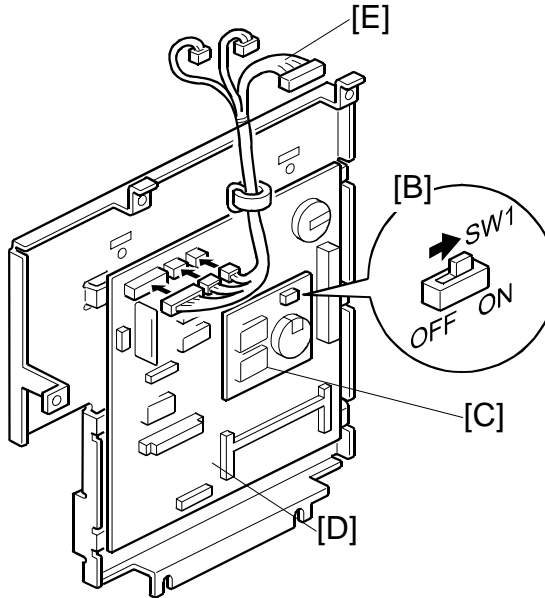

B5021111.WMF

11. Turn the MBU battery switch (SW1) [B] on.

NOTE: The MBU [C] is on the FCU [D].

12. Connect the harness [E] to the FCU (⚙️ x 2 for the U.S. version, ⚙️ x 3 for the non-U.S. version).

NOTE: Connect the blue connector to the blue socket.

U.S. VERSION

NON-U.S. VERSION

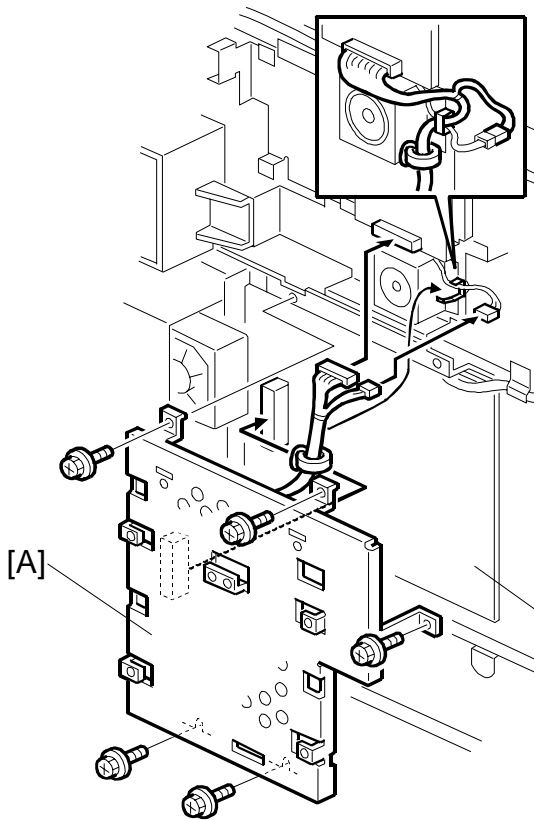

B5021005.WMF

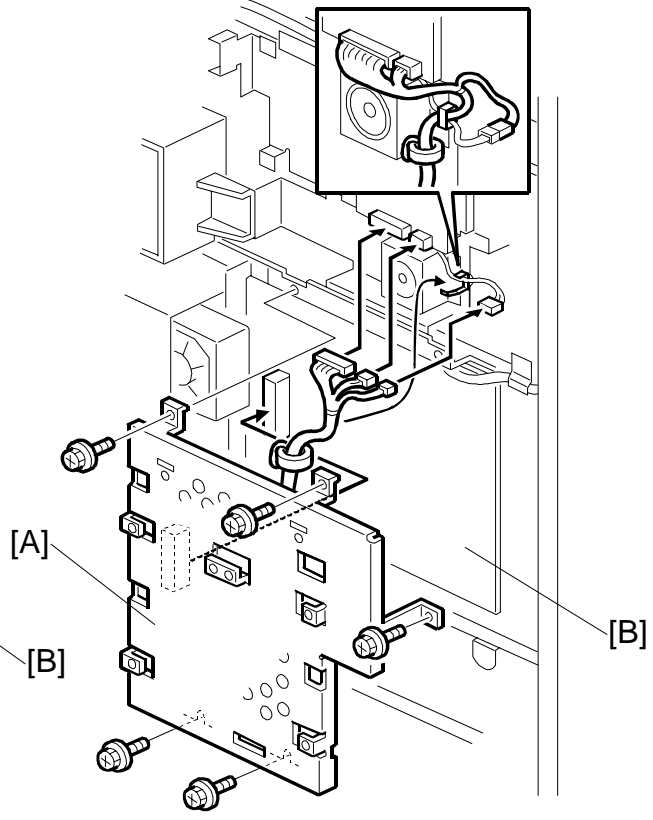

B5021105.WMF

13. Connect the FCU [A] to the BiCU [B] and install it in the copier (⌀ x 5).
14. For the U.S. version, connect one connector to the NCU and the other one to the speaker connector. For the non-U.S. version, connect two connectors to the NCU and the other one to the speaker.
15. Reattach the BCU cover, the fan with the bracket, and the ground bracket.
NOTE: When reassembling, use caution not to damage harnesses and electrical circuits.

- 16. Replace the dummy keypad [A] with the fax keypad [B].
- 17. Replace the third key-slot cover [C] with the fax key [D].

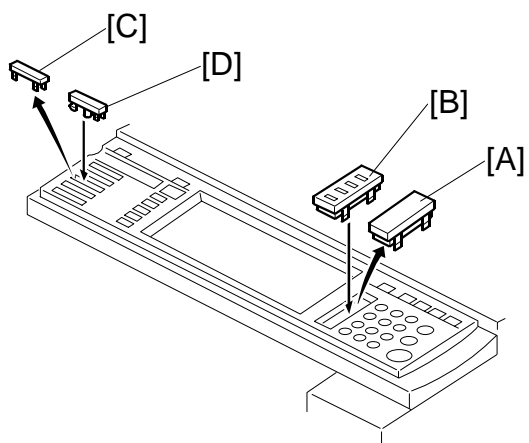

Installation

B5021007.WMF

- 18. Attach the decal (*SUPER G3*) [E] to the front cover.

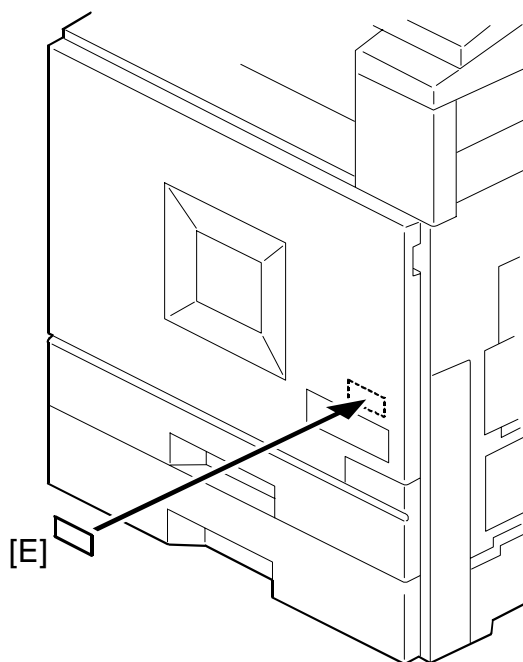

B5021008.WMF

19. Install the stamp cartridge [A] if the ARDF [B] has been installed.

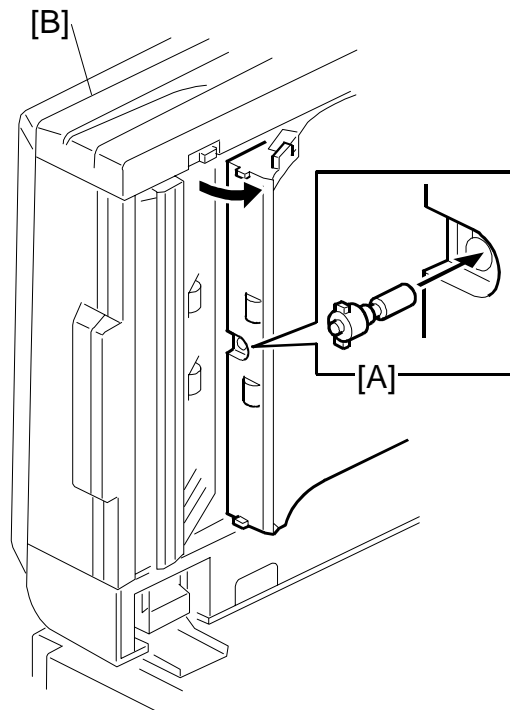

B5021006.WMF

20. Reattach the rear cover (⚙ x 2).
21. Attach the FCC decal [C] and serial number decal [D].
- NOTE:** The FCC decal is for the U.S. and Canada only.

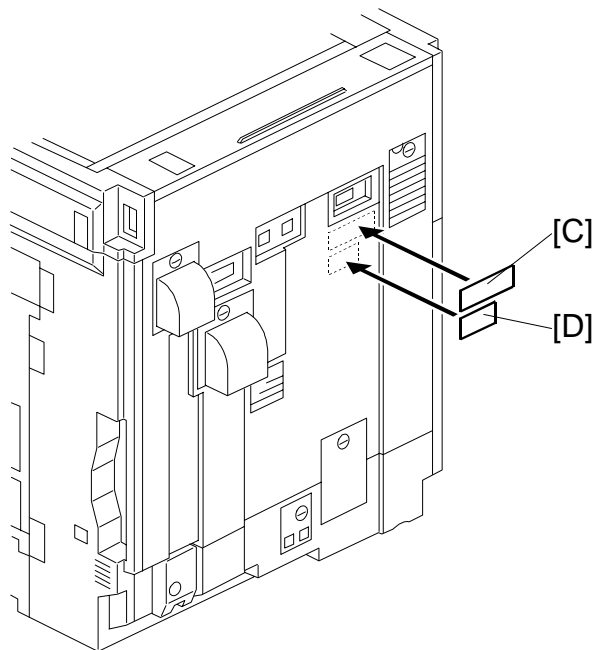

B5021018.WMF

22. Connect the telephone line to the *LINE* jack [A].
NOTE: For the European and Asian models, attach the ferrite core [B] to the telephone line.
23. Put the power plug into the outlet and turn the main switch on.
NOTE: Make sure that the outlet is grounded.

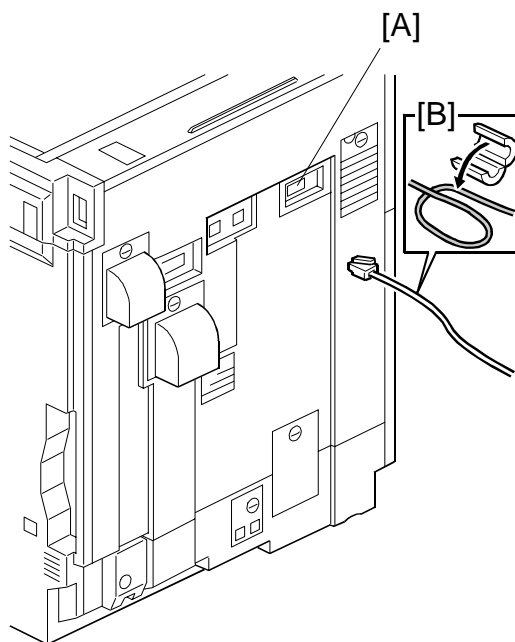

Installation

B5021113.WMF

24. Wait until the following messages are displayed:
Function Problems
Functional problems with facsimile.
Data will be initialized.
25. Touch "OK" on the screen. The initialization starts.
26. Make sure that the date and time are correctly set.

1.2 FAX UNIT OPTIONS

1.2.1 G3 INTERFACE UNIT

⚠ CAUTION

Before installing this optional unit,

- 1) Print out all data in the printer buffer if there is an optional printer installed.
- 2) Turn off the main switch and disconnect the power cord and the network cable.

1. Remove the rear cover [A] (⚙ x 2).
2. Remove the right connector shield [B].
3. When installing *ISDN Option Type 1232*, cut away the left connector shield [C] and file the edges smooth.

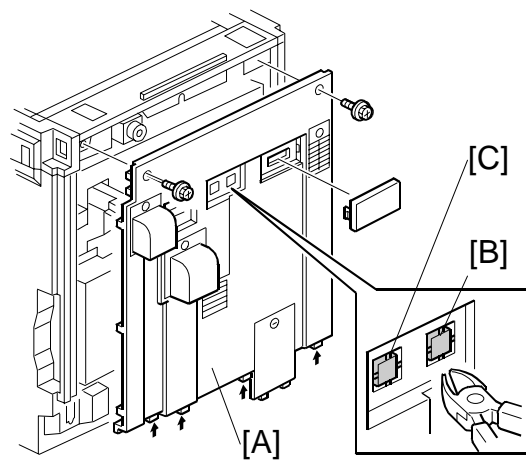

B5021003.WMF

4. Remove the fan with the bracket [D] (⚙ x 5, ⚙ x 1).
5. Remove the ground bracket [E] (⚙ x 3).
6. Remove the BCU cover [F] (⚙ x 13).

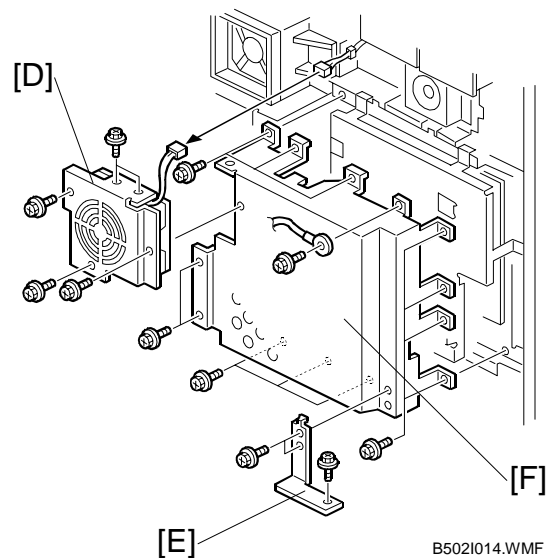

B5021014.WMF

U.S. VERSION

NON-U.S. VERSION

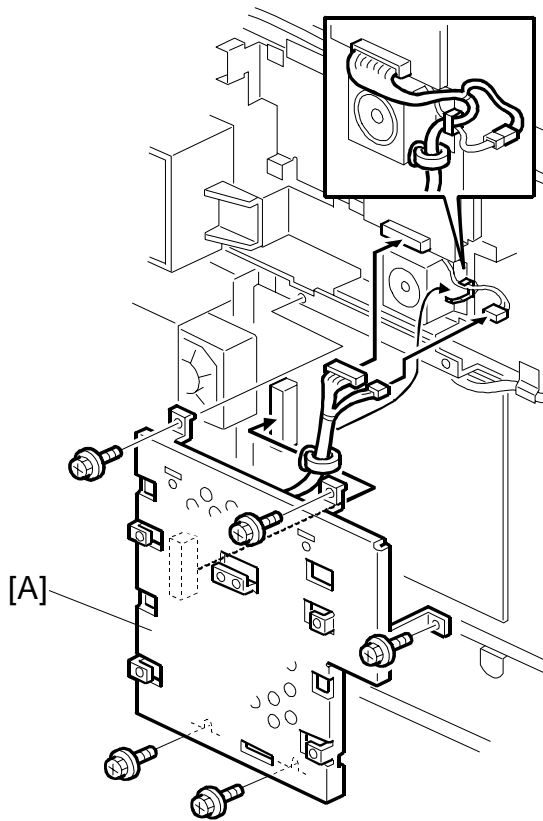

B5021005.WMF

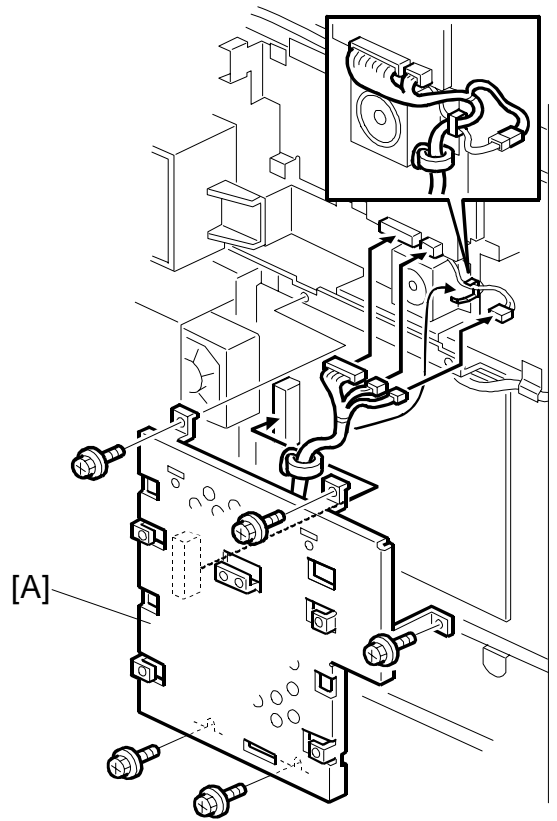

B5021105.WMF

7. Remove the FCU [A] (⚙ x 2 for the U.S. version/⚙ x 3 for the non-U.S. version, ⚙ x 5).

8. Attach the CCU interface [B] to the FCU bracket [C] (⚙ x 4).

NOTE: The *G3 Interface Unit Type 1232* package contains one CCU interface, and so does the *ISDN Option Type 1232* package. When installing the two optional units at once, only one of the two interfaces is necessary.

9. Connect the flat cable [D] to the blue side outside.

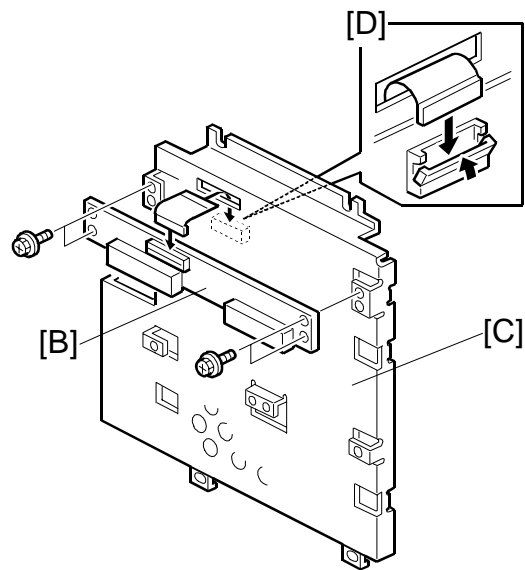

B5021002.WMF

- 10. Attach the G3 bracket [A] (⌀ x 3).
- 11. Connect the SG3-D [B] to the CCU interface [C] and secure it (⌀ x 2).

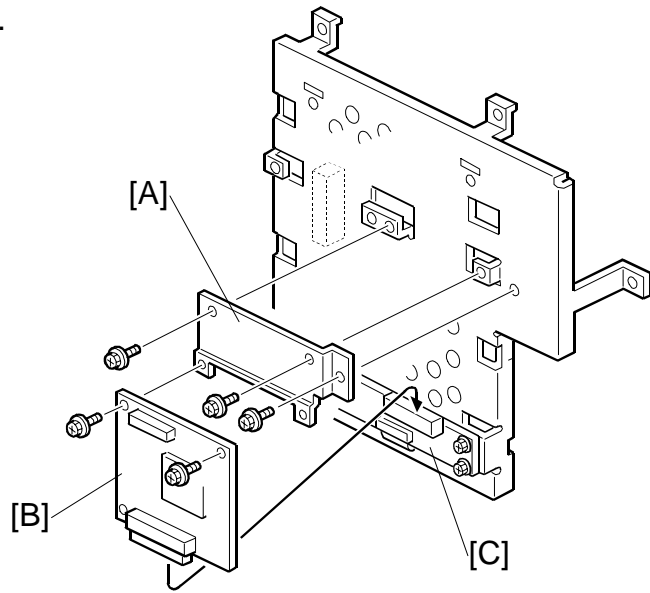

B5021052.WMF

U.S. VERSION

NON-U.S. VERSION

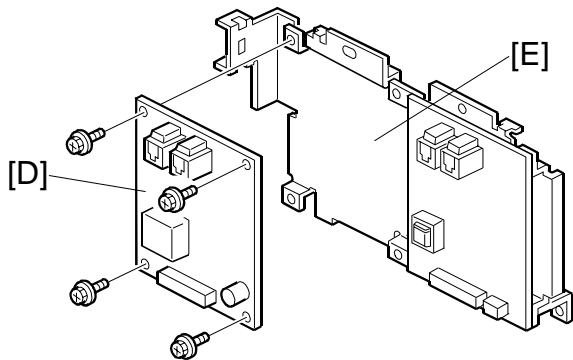

B5021151.WMF

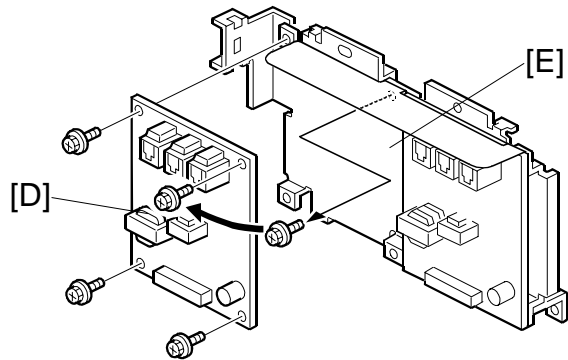

B5021054.WMF

- 12. Attach the NCU [D] to the NCU bracket [E] (⌀ x 4).
- NOTE:** On the NCU bracket of the non-U.S. version, a mylar sheet is attached with two screws. Remove the left screw, and use it to install the NCU.

13. Set up the jumper switches [A and B] on the NCU.

NOTE: NOTE: European/Asian models only (non-U.S. version: B503-27)

		TB1 [A]	TB2 [B]
Default		ON	ON
Region/ Country	Hong Kong	OFF	OFF
	Hungary	ON	ON
	Poland	ON	ON
	Czech Republic	ON	ON
	Israel	ON	ON
	South Africa	ON	ON
	Regions/countries where the CTR21 standard is valid	ON	ON
	Other	ON	OFF

TB1 ON: Keep the jumper attached (factory setting). OFF: Remove the jumper.

TB2 ON: Keep the jumper at ON (factory setting). OFF: Move the jumper to OFF.

NOTE: You must change the country code in both system switch 0F and NCU parameter CC (service function 08-0).

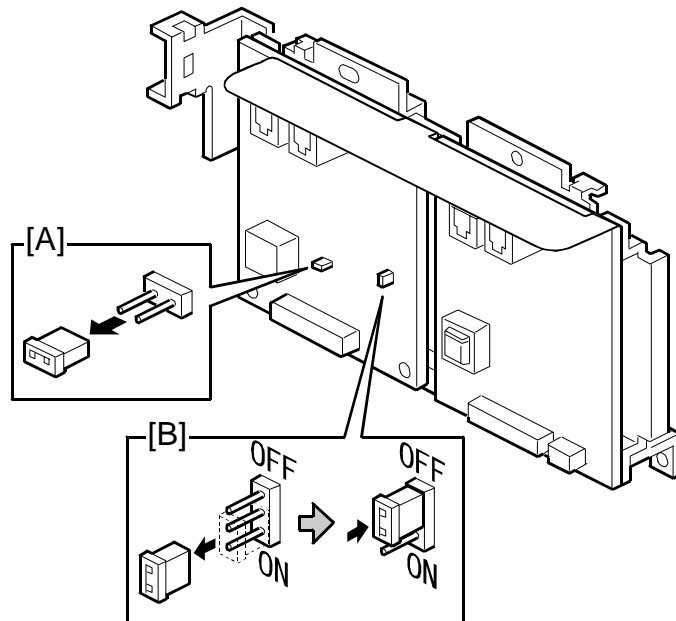

B5021155.WMF

U.S. VERSION

NON-U.S. VERSION

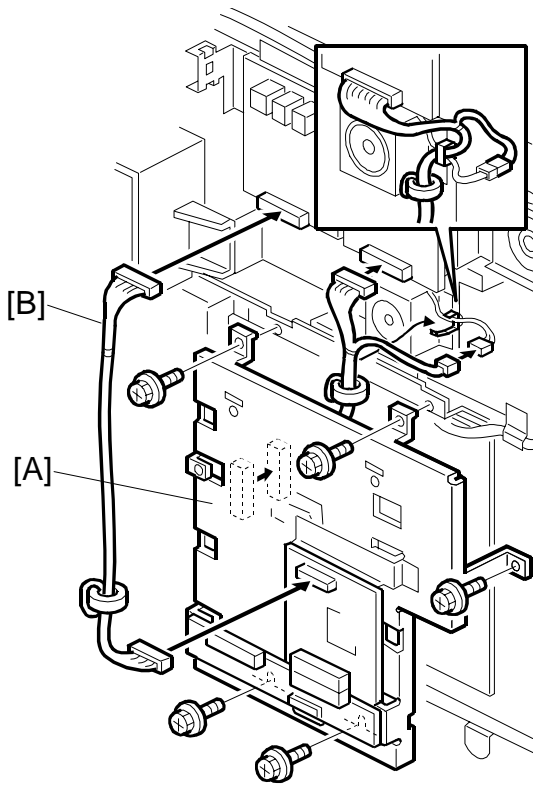

B5021053.WMF

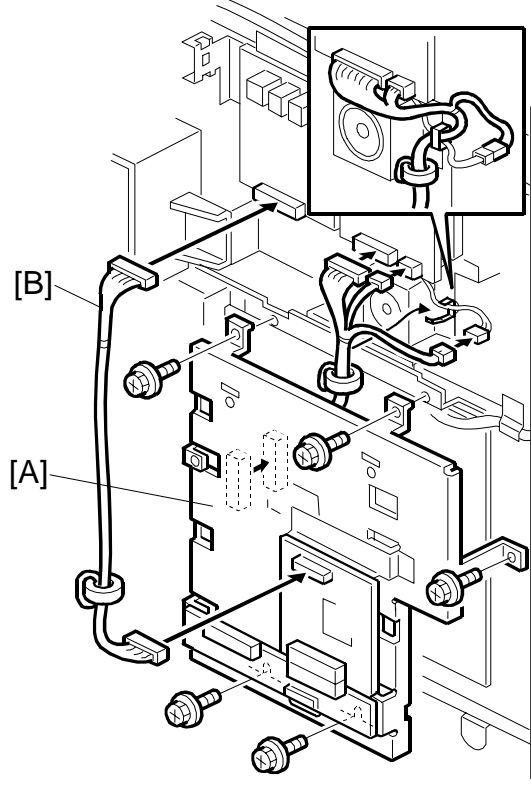

B5021153.WMF

14. Attach the FCU [A] to the copier and connect the connectors (☐ x 4 for the U.S. version/☐ x 5 for the non-U.S. version).
15. Connect the harness [B] to the SG3-D and the NCU.
NOTE: The ferrite core is near the lower connector.
16. Attach the cable clamp [C].
NOTE: When installing both *G3 Interface Unit Type 1232* and *ISDN Option Type 1232*, attach the G3 clamp [C] to the right side and the ISDN clamp [D] to the left side.
17. Reattach the BCU cover, the fan with the bracket, and the ground bracket.
NOTE: When reassembling, use caution not to damage harnesses and electrical circuits.

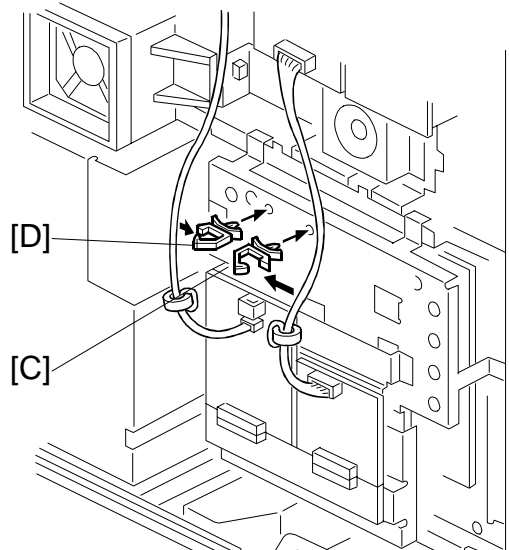

B5021015.WMF

18. Reattach the rear cover (⌀ x 2).
19. Attach the FCC decal [A] right above the *LINE 2* jack.
NOTE: The FCC decal is for U.S. and Canada only.

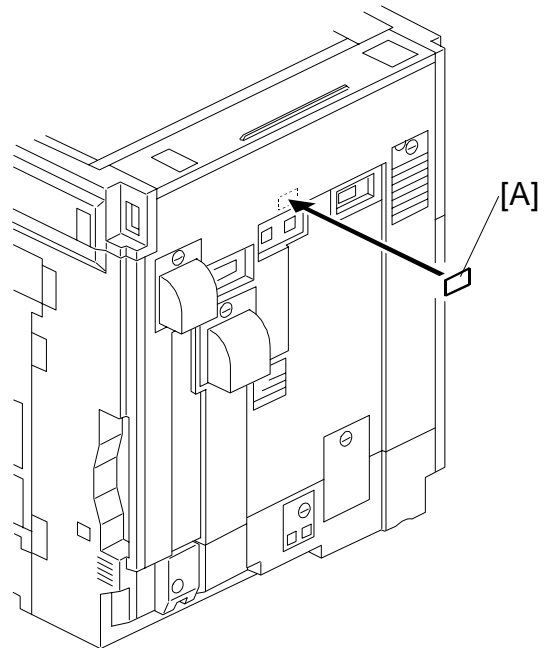

B5021016.WMF

20. Connect the telephone line to the *LINE 2* jack [B].
21. Attach the ferrite core [C] to the telephone line.
22. Put the power plug into the outlet and turn the main switch on.
NOTE: Make sure that the outlet is grounded.
23. Start the service mode and set bit 1 of communication switch 16 to "1" (SP1-104-023).
24. Turn the main switch off and on.
25. Print out the system parameter list and check that "SG3-D" is listed as an option (SP6-101).
26. Set up and program the items required for PSTN-2 communications.
27. Turn the main switch off and on.

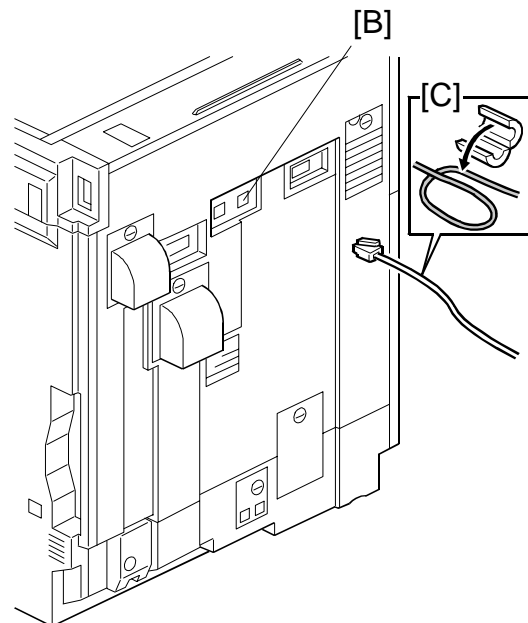

B5021113.WMF

1.2.2 ISDN OPTION

⚠ CAUTION

Before installing this optional unit,

- 1) Print out all data in the printer buffer if there is an optional printer installed.**
- 2) Turn off the main switch and disconnect the power cord and the network cable.**

1. Remove the rear cover [A] (⚙ x 2).
2. Remove the left connector shield [B].
3. When installing *G3 Interface Unit Type 1232*, cut away the right connector shield [C] and file the edges smooth.

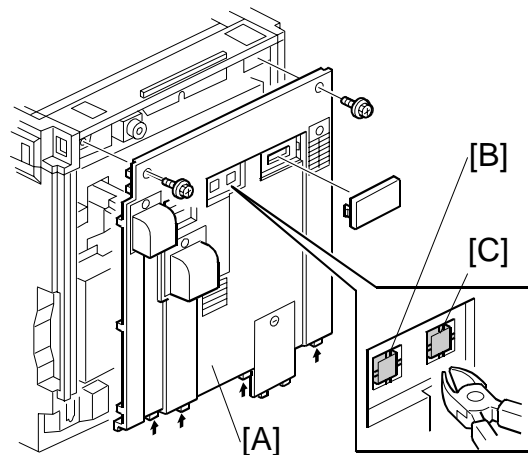

B5021003.WMF

4. Remove the fan with the bracket [D] (⚙ x 5, ⚙ x 1).
5. Remove the ground bracket [E] (⚙ x 3).
6. Remove the BCU cover [F] (⚙ x 13).

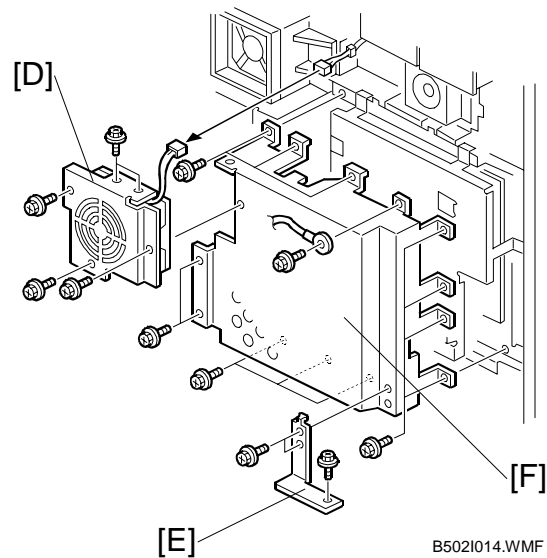

B5021014.WMF

U.S. VERSION

NON-U.S. VERSION

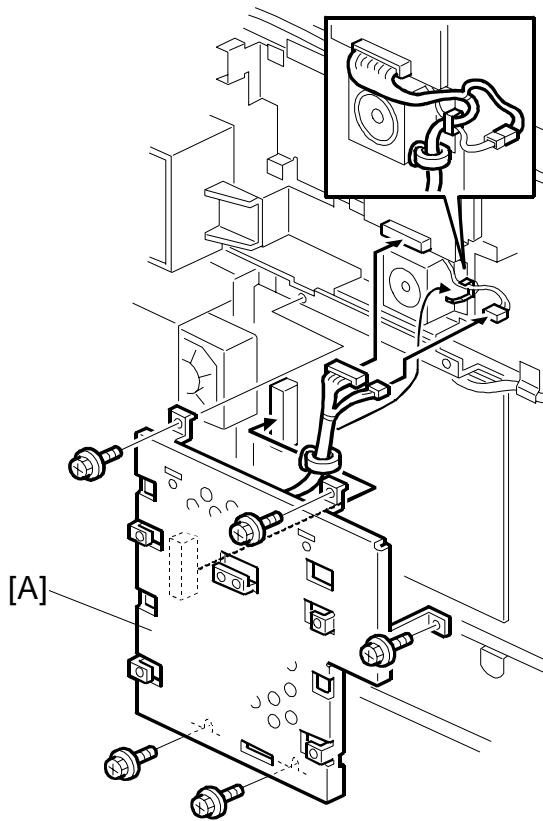

B5021005.WMF

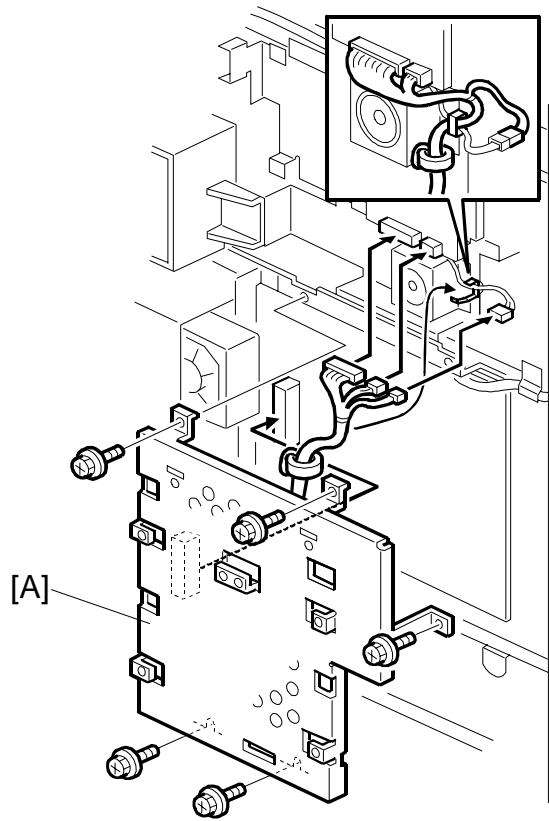

B5021105.WMF

7. Remove the FCU [A] (⌘ x 2 for the U.S. version/⌘ x 3 for the non-U.S. version, ⌘ x 5)

8. Attach the CCU interface [B] to the FCU bracket [C] (⌘ x 4).

NOTE: The *G3 Interface Unit Type 1232* package contains one CCU interface, and so does the *ISDN Option Type 1232* package. When installing the two optional units at once, only one of the two interfaces is necessary.

9. Connect the flat cable [D] with the blue side outside.

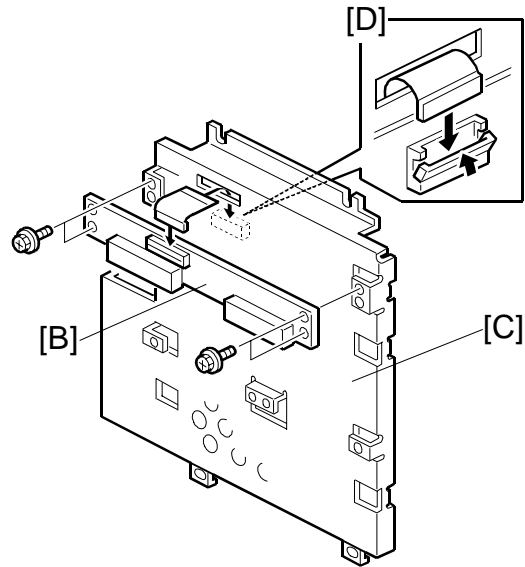

B5021002.WMF

10. Connect the SiG4 [A] to the CCU interface [B] and secure it (⚙ x 2).

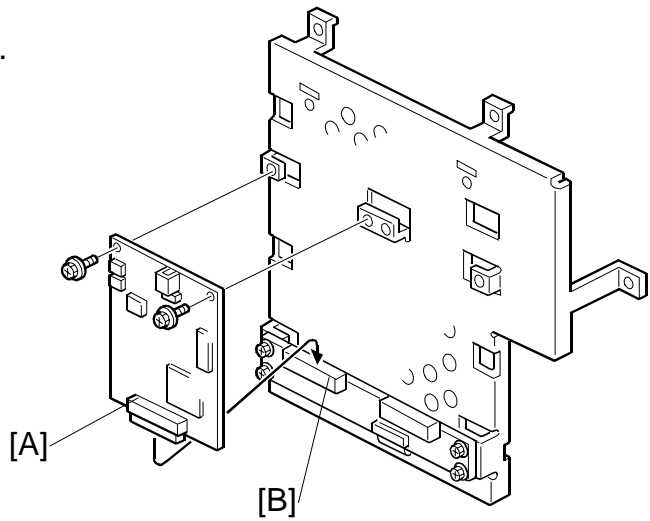

B5021101.WMF

U.S. VERSION

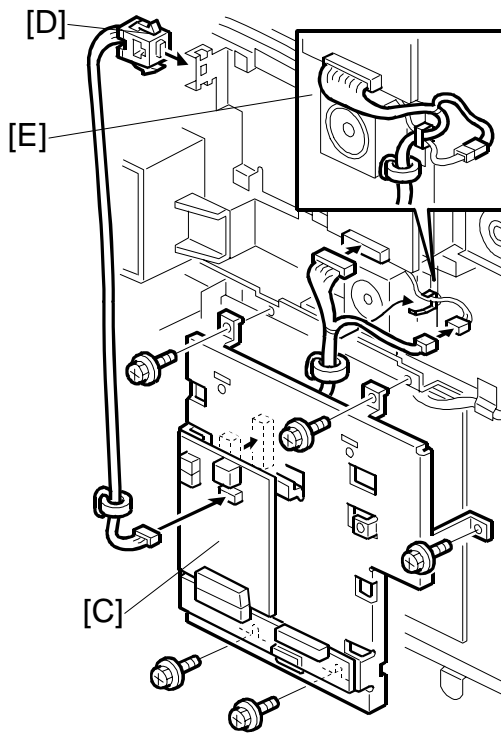

B5021102.WMF

NON-U.S. VERSION

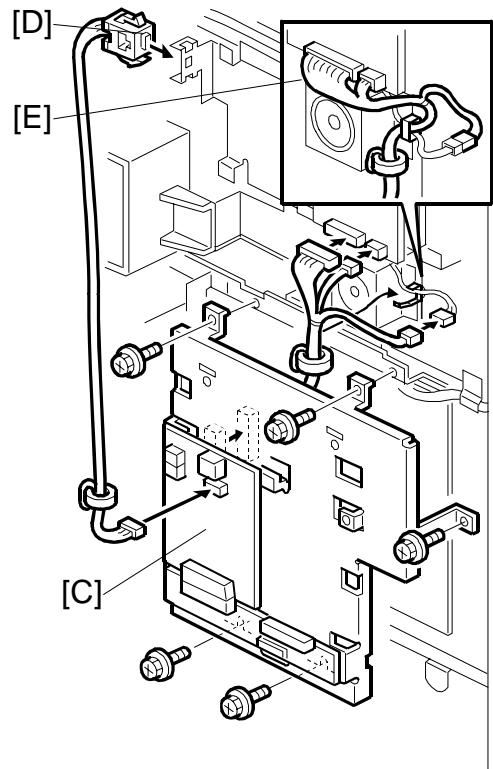

B5021152.WMF

11. Attach the FCU [C] to the copier and connect the connectors (⚙ x 3 for the U.S. version/⚙ x 4 for the non-U.S. version).

12. Install the modular jack [D] on the NCU bracket [E], and connect the connector.

13. Attach the cable clamp [A].
NOTE: When installing both *G3 Interface Unit Type 1232* and *ISDN Option Type 1232*, attach the G3 clamp [B] to the right side and the ISDN clamp [A] to the left side.
14. Reattach the BCU cover, the fan with the bracket, and the ground bracket.
NOTE: When reassembling, use caution not to damage harnesses and electrical circuits.

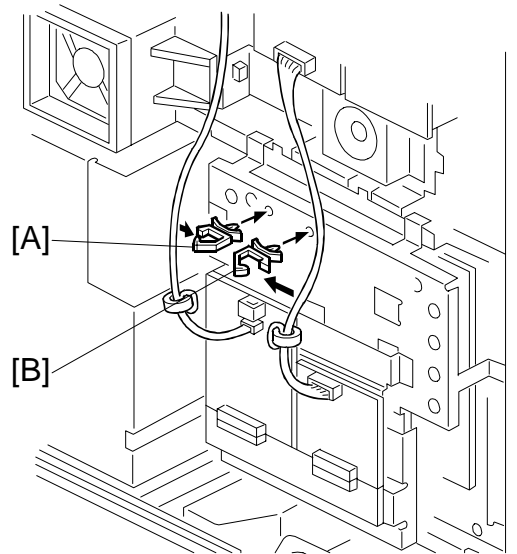

B5021015.WMF

15. Reattach the rear cover (⚙ x 2).
16. Attach the FCC decal [C] right above the *ISDN* jack.
NOTE: The FCC decal is for U.S. and Canada only.

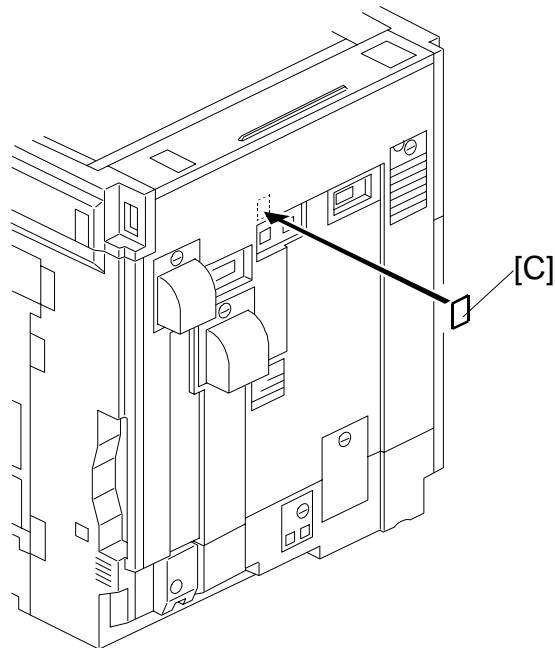

B5021017.WMF

17. Connect the telephone line to the *ISDN* jack [A].

NOTE: For the European and Asian models, attach the ferrite core [B] to the telephone line.

18. Put the power plug into the outlet and turn the main switch on.
NOTE: Make sure that the outlet is grounded.
19. Start the service mode and set bit 2 of communication switch 16 to "1" (SP1-104-023).
20. Turn the main switch off and on.
21. Print out the system parameter list and check that "G4" is listed as an option (SP6-101).
22. Set up and program the items required for ISDN communications.
23. Turn the main switch off and on.

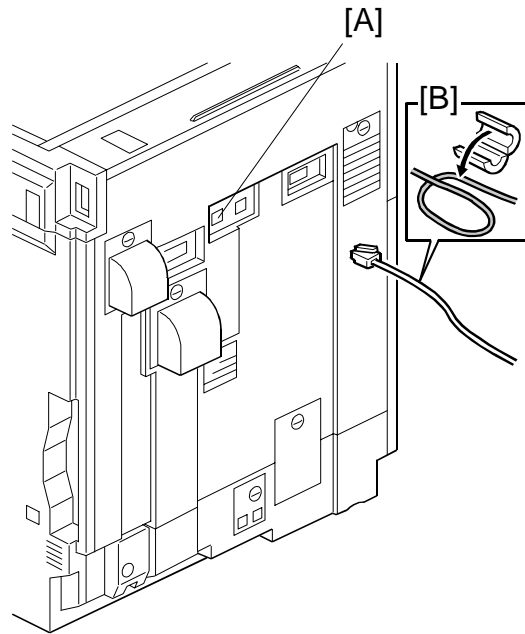

B5021113.WMF

1.2.3 EXPANSION MEMORY

NOTE: Expansion memories are not provided. Locally procure an expansion memory that meets the specifications (same as other recent models — see the specifications section).

1. Remove the rear cover (⚙️ x 2).
2. Remove the fan with the bracket (⚙️ x 5, 🛠️ x 1).
3. Remove the ground bracket (⚙️ x 3).
4. Remove the BCU cover (⚙️ x 13).
5. Remove the FCU (⚙️ x 5, 🛠️ x 2 [U.S. version]/ 🛠️ x 3 [non-U.S. version]).
6. Install an expansion memory [A].
7. Turn the MBU battery switch [B] (SW1) on, or check that the switch has been already turned on.

NOTE: The MBU battery switch (SW1) has been already turned on if the fax unit has been correctly installed.

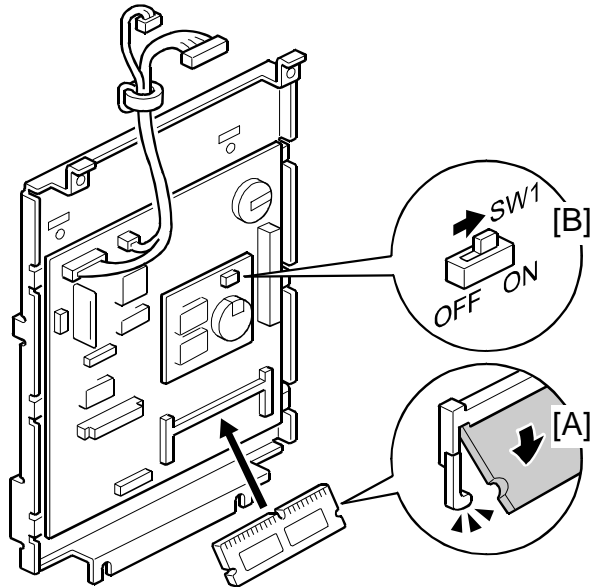

B5021009.WMF

1.2.4 FAX FUNCTION UPGRADE KIT

1. Remove the rear cover (⚙️ x 2).
2. Remove the fan with the bracket (⚙️ x 5, 🛠️ x 1).
3. Remove the ground bracket (⚙️ x 3).
4. Remove the BCU cover (⚙️ x 13).
5. Remove the FCU (⚙️ x 5, 🛠️ x 2 [U.S. version]/ 🛠️ x 3 [non-U.S. version]).
6. Turn the MBU battery switch [A] (SW1) on, or check that the switch has been already turned on.
NOTE: The MBU battery switch (SW1) has been already turned on if the fax unit has been correctly installed.

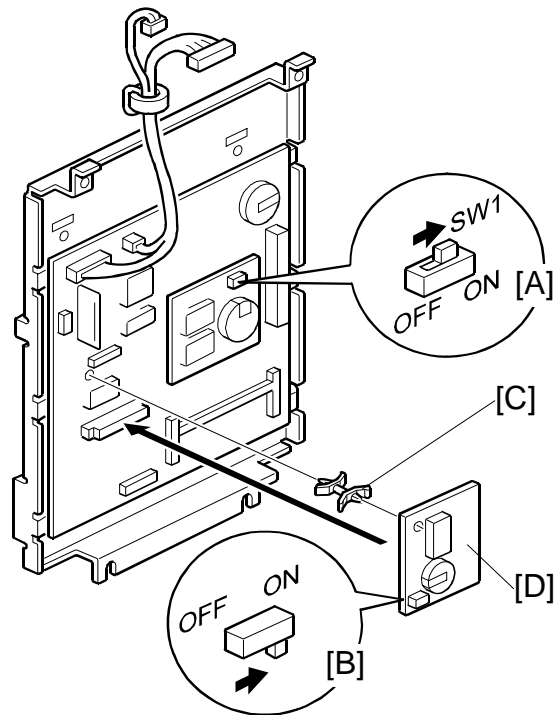

B5021010.WMF

7. Turn the *Fax Function Upgrade Kit* battery switch [B] (SW1) on.
8. Install the double-locking spacer [C].
9. Install the *Fax Function Upgrade Kit* [D].
10. Turn the main switch on.
11. Wait until the message and “Execute” are displayed on the touch screen.
12. Touch “Execute” to initialize the program.
13. Set the system switch 1E Bit 7 to “1” (SP1-101-031).

1.2.5 HANDSET

NOTE: The optional handset is available for the U.S. version only.

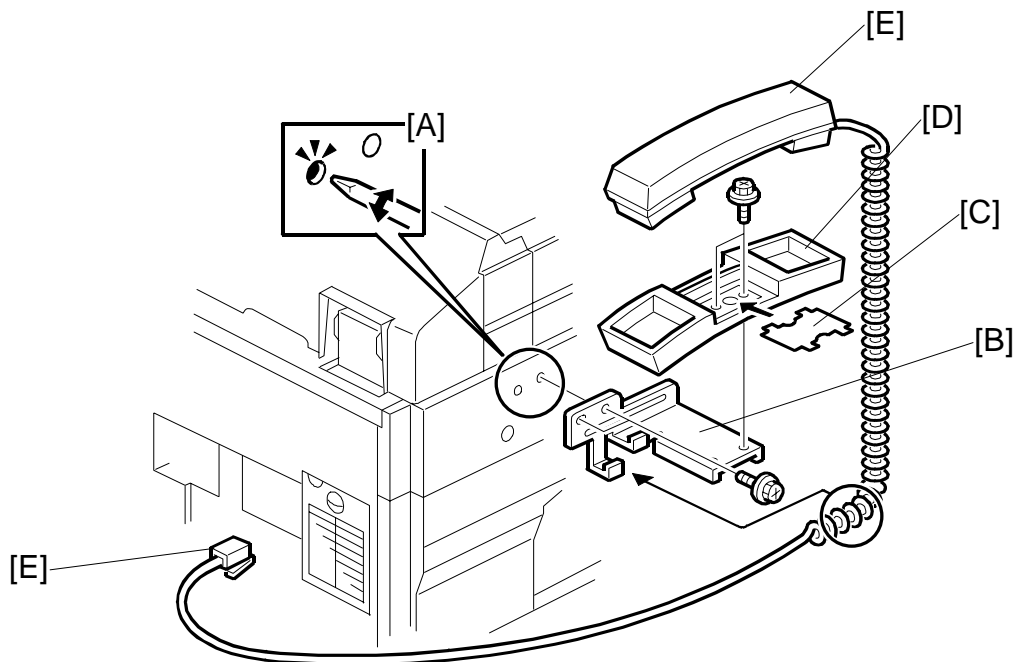

B5021114.WMF

1. Make two holes [A] in the scanner left cover.
2. Attach the bracket [B] enclosed with the fax unit (⚙ x 2) as shown.
3. Remove the label [C] from the handset cradle [D]. Attach the cradle [D] to the bracket [B] (⚙ x 2), then replace the label [C].
4. Install the handset [E] on the cradle [B].
5. Connect the cable [F] to the "TEL" jack at the rear of the machine.

2. REPLACEMENT AND ADJUSTMENT

2.1 NOTES FOR FCU BOARD REPLACEMENT

1. When replacing the FCU board, remove the MBU board from the old FCU board and install it on the new FCU board.
2. Adjust the date and time (UP — System Settings — Timer Setting — Set Date/Set Time).

NOTE: 1) Do not turn off the battery switch (SW1).
2) Print out the system parameter list (SP6-101), group dial list, quick dial list, and speed dial list (UP) to confirm the settings.

Replacement
Adjustment

3. TROUBLESHOOTING

3.1 ERROR CODES

If an error code occurs, retry the communication. If the same problem occurs, try to fix the problem as suggested below. Note that some error codes appear only in the error code display and on the service report.

Code	Meaning	Suggested Cause/Action
0-00	DIS/NSF not detected within 40 s of Start being pressed	<ul style="list-style-type: none"> • Check the line connection. • Check the NCU - FCU connectors. • The machine at the other end may be incompatible. • Replace the NCU or FCU. • Check for DIS/NSF with an oscilloscope. • If the rx signal is weak, there may be a bad line.
0-01	DCN received unexpectedly	<ul style="list-style-type: none"> • The other party is out of paper or has a jammed printer. • The other party pressed Stop during communication.
0-03	Incompatible modem at the other end	<ul style="list-style-type: none"> • The other terminal is incompatible.
0-04	CFR or FTT not received after modem training	<ul style="list-style-type: none"> • Check the line connection. • Check the NCU - FCU connectors. • Try changing the tx level and/or cable equalizer settings. • Replace the FCU or NCU. • The other terminal may be faulty; try sending to another machine. • If the rx signal is weak or defective, there may be a bad line. <p>Cross reference</p> <ul style="list-style-type: none"> • Tx level - NCU Parameter 01 (PSTN) • Cable equalizer - G3 Switch 07 (PSTN) • Dedicated Tx parameters - Section 4
0-05	Unsuccessful after modem training at 2400 bps	<ul style="list-style-type: none"> • Check the line connection. • Check the NCU - FCU connectors. • Try adjusting the tx level and/or cable equalizer. • Replace the FCU or NCU. • Check for line problems. <p>Cross reference</p> <ul style="list-style-type: none"> • See error code 0-04.

Code	Meaning	Suggested Cause/Action
0-06	The other terminal did not reply to DCS	<ul style="list-style-type: none"> • Check the line connection. • Check the FCU - NCU connectors. • Try adjusting the tx level and/or cable equalizer settings. • Replace the NCU or FCU. • The other end may be defective or incompatible; try sending to another machine. • Check for line problems. <p>Cross reference</p> <ul style="list-style-type: none"> • See error code 0-04.
0-07	No post-message response from the other end after a page was sent	<ul style="list-style-type: none"> • Check the line connection. • Check the FCU - NCU connectors. • Replace the NCU or FCU. • The other end may have jammed or run out of paper. • The other end user may have disconnected the call. • Check for a bad line. • The other end may be defective; try sending to another machine.
0-08	The other end sent RTN or PIN after receiving a page, because there were too many errors	<ul style="list-style-type: none"> • Check the line connection. • Check the FCU - NCU connectors. • Replace the NCU or FCU. • The other end may have jammed, or run out of paper or memory space. • Try adjusting the tx level and/or cable equalizer settings. • The other end may have a defective modem/NCU/FCU; try sending to another machine. • Check for line problems and noise. <p>Cross reference</p> <ul style="list-style-type: none"> • Tx level - NCU Parameter 01 (PSTN) • Cable equalizer - G3 Switch 07 (PSTN) • Dedicated Tx parameters - Section 4
0-14	Non-standard post message response code received	<ul style="list-style-type: none"> • Check the FCU - NCU connectors. • Incompatible or defective remote terminal; try sending to another machine. • Noisy line: resend. • Try adjusting the tx level and/or cable equalizer settings. • Replace the NCU or FCU. <p>Cross reference</p> <ul style="list-style-type: none"> • See error code 0-08.

Code	Meaning	Suggested Cause/Action
0-15	The other terminal is not capable of specific functions.	<p>The other terminal is not capable of accepting the following functions, or the other terminal's memory is full.</p> <ul style="list-style-type: none"> • Confidential rx • Transfer function • SEP/SUB/PWD/SID
0-16	CFR or FTT not detected after modem training in confidential or transfer mode	<ul style="list-style-type: none"> • Check the line connection. • Check the FCU - NCU connectors. • Replace the NCU or FCU. • Try adjusting the tx level and/or cable equalizer settings. • The other end may have disconnected, or it may be defective; try calling another machine. • If the rx signal level is too low, there may be a line problem. <p>Cross reference</p> <ul style="list-style-type: none"> • See error code 0-08.
0-17	Communication was interrupted by pressing the Stop key.	If the Stop key was not pressed and this error keeps occurring, replace the operation panel.
0-20	Facsimile data not received within 6 s of retraining	<ul style="list-style-type: none"> • Check the line connection. • Check the FCU - NCU connectors. • Replace the NCU or FCU. • Check for line problems. • Try calling another fax machine. • Try adjusting the reconstruction time for the first line and/or rx cable equalizer setting. <p>Cross reference</p> <ul style="list-style-type: none"> • Reconstruction time - G3 Switch 0A, bit 6 • Rx cable equalizer - G3 Switch 07 (PSTN)
0-21	EOL signal (end-of-line) from the other end not received within 5 s of the previous EOL signal	<ul style="list-style-type: none"> • Check the connections between the FCU, NCU, & line. • Check for line noise or other line problems. • Replace the NCU or FCU. • The remote machine may be defective or may have disconnected. <p>Cross reference</p> <ul style="list-style-type: none"> • Maximum interval between EOLs and between ECM frames - G3 Bit Switch 0A, bit 4
0-22	The signal from the other end was interrupted for more than the acceptable modem carrier drop time (default: 200 ms)	<ul style="list-style-type: none"> • Check the line connection. • Check the FCU - NCU connectors. • Replace the NCU or FCU. • Defective remote terminal. • Check for line noise or other line problems. • Try adjusting the acceptable modem carrier drop time. <p>Cross reference</p> <ul style="list-style-type: none"> • Acceptable modem carrier drop time - G3 Switch 0A, bits 0 and 1

Code	Meaning	Suggested Cause/Action
0-23	Too many errors during reception	<ul style="list-style-type: none"> • Check the line connection. • Check the FCU - NCU connectors. • Replace the NCU or FCU. • Defective remote terminal. • Check for line noise or other line problems. • Try asking the other end to adjust their tx level. • Try adjusting the rx cable equalizer setting and/or rx error criteria. <p>Cross reference</p> <ul style="list-style-type: none"> • Rx cable equalizer - G3 Switch 07 (PSTN) • Rx error criteria - Communication Switch 02, bits 0 and 1
0-30	The other terminal did not reply to NSS(A) in AI short protocol mode	<ul style="list-style-type: none"> • Check the line connection. • Check the FCU - NCU connectors. • Try adjusting the tx level and/or cable equalizer settings. • The other terminal may not be compatible. <p>Cross reference</p> <ul style="list-style-type: none"> • Dedicated tx parameters - Section 4
0-32	The other terminal sent a DCS, which contained functions that the receiving machine cannot handle.	<ul style="list-style-type: none"> • Check the protocol dump list. • Ask the other party to contact the manufacturer.
0-52	Polarity changed during communication	<ul style="list-style-type: none"> • Check the line connection. • Retry communication.
0-70	The communication mode specified in CM/JM was not available (V.8 calling and called terminal)	<ul style="list-style-type: none"> • The other terminal did not have a compatible communication mode (e.g., the other terminal was a V.34 data modem and not a fax modem.) • A polling tx file was not ready at the other terminal when polling rx was initiated from the calling terminal.
0-74	The calling terminal fell back to T.30 mode, because it could not detect ANSam after sending CI.	<ul style="list-style-type: none"> • The calling terminal could not detect ANSam due to noise, etc. • ANSam was too short to detect. • Check the line connection and condition. • Try making a call to another V.8/V.34 fax.
0-75	The called terminal fell back to T.30 mode, because it could not detect a CM in response to ANSam (ANSam timeout).	<ul style="list-style-type: none"> • The terminal could not detect ANSam. • Check the line connection and condition. • Try receiving a call from another V.8/V.34 fax.
0-76	The calling terminal fell back to T.30 mode, because it could not detect a JM in response to a CM (CM timeout).	<ul style="list-style-type: none"> • The called terminal could not detect a CM due to noise, etc. • Check the line connection and condition. • Try making a call to another V.8/V.34 fax.

Code	Meaning	Suggested Cause/Action
0-77	The called terminal fell back to T.30 mode, because it could not detect a CJ in response to JM (JM timeout).	<ul style="list-style-type: none"> The calling terminal could not detect a JM due to noise, etc. A network that has narrow bandwidth cannot pass JM to the other end. Check the line connection and condition. Try receiving a call from another V.8/V.34 fax.
0-79	The called terminal detected CI while waiting for a V.21 signal.	Check for line noise or other line problems. If this error occurs, the called terminal falls back to T.30 mode.
0-80	The line was disconnected due to a timeout in V.34 phase 2 – line probing.	<ul style="list-style-type: none"> The guard timer expired while starting these phases. Serious noise, narrow bandwidth, or low signal level can cause these errors.
0-81	The line was disconnected due to a timeout in V.34 phase 3 – equalizer training.	If these errors happen at the transmitting terminal: <ul style="list-style-type: none"> Try making a call at a later time. Try using V.17 or a slower modem using dedicated tx parameters.
0-82	The line was disconnected due to a timeout in the V.34 phase 4 – control channel start-up.	<ul style="list-style-type: none"> Try increasing the tx level. Try adjusting the tx cable equalizer setting.
0-83	The line was disconnected due to a timeout in the V.34 control channel restart sequence.	If these errors happen at the receiving terminal: <ul style="list-style-type: none"> Try adjusting the rx cable equalizer setting. Try increasing the tx level. Try using V.17 or a slower modem if the same error is frequent when receiving from multiple senders.
0-84	The line was disconnected due to abnormal signaling in V.34 phase 4 – control channel start-up.	<ul style="list-style-type: none"> The signal did not stop within 10 s. Turn off the machine, then turn it back on. If the same error is frequent, replace the FCU.
0-85	The line was disconnected due to abnormal signaling in V.34 control channel restart.	<ul style="list-style-type: none"> The signal did not stop within 10 s. Turn off the machine, then turn it back on. If the same error is frequent, replace the FCU.
0-86	The line was disconnected because the other terminal requested a data rate using MPh that was not available in the currently selected symbol rate.	<ul style="list-style-type: none"> The other terminal was incompatible. Ask the other party to contact the manufacturer.
0-87	The control channel started after an unsuccessful primary channel.	<ul style="list-style-type: none"> The receiving terminal restarted the control channel because data reception in the primary channel was not successful. This does not result in an error communication.
0-88	The line was disconnected because PPR was transmitted/received 9 (default) times within the same ECM frame.	<ul style="list-style-type: none"> Try using a lower data rate at the start. Try adjusting the cable equalizer setting.
2-10	The modem cannot enter tx mode	<ul style="list-style-type: none"> Replace the FCU.
2-11	Only one V.21 connection flag was received	<ul style="list-style-type: none"> Replace the FCU.
2-12	Modem clock irregularity	<ul style="list-style-type: none"> Replace the FCU.

Code	Meaning	Suggested Cause/Action
2-13	Modem initialization error	<ul style="list-style-type: none"> • Turn off the machine, then turn it back on. • Update the modem ROM. • Replace the FCU.
2-20	Abnormal coding/decoding (cpu not ready)	<ul style="list-style-type: none"> • Replace the FCU.
2-23	JBIG compression or reconstruction error	<ul style="list-style-type: none"> • Turn off the machine, then turn it back on. • Replace the EXFUNC board if the error is frequent.
2-24	JBIG ASIC error	<ul style="list-style-type: none"> • Turn off the machine, then turn it back on. • Replace the EXFUNC board if the error is frequent.
2-25	JBIG data reconstruction error (BIH error)	<ul style="list-style-type: none"> • JBIG data error • Check the sender's JBIG function. • Update the MBU ROM.
2-26	JBIG data reconstruction error (Float marker error)	
2-27	JBIG data reconstruction error (End marker error)	
2-28	JBIG data reconstruction error (Timeout)	
2-50	The machine resets itself for a fatal FCU system error	<ul style="list-style-type: none"> • If this is frequent, update the ROM, or replace the FCU.
2-51	The machine resets itself because of a fatal communication error	<ul style="list-style-type: none"> • If this is frequent, update the ROM, or replace the FCU.
3-00	G4 interface board reset	<ul style="list-style-type: none"> • Replace the G4 interface board or FCU.
3-10	Disconnection during ISDN G3 communication	<ul style="list-style-type: none"> • Check the other terminal and the ISDN line. • The other terminal may have dialed a wrong number.
3-11	Disconnection during ISDN G4 communication	<ul style="list-style-type: none"> • Check the other terminal and the ISDN line.
3-20	A CSA signal was received during ISDN G4 communication	<ul style="list-style-type: none"> • The operator at the other terminal may have interrupted the communication.
3-21	A CSA signal was sent during ISDN G4 communication, because the Stop key was pressed	<ul style="list-style-type: none"> • The local operator has interrupted the communication.
3-30	Mismatched specifications (rx capability)	<ul style="list-style-type: none"> • Check the receive capabilities requested from the other terminal.
4-01	Line current was cut	<ul style="list-style-type: none"> • Check the line connector. • Check the connection between FCU and NCU. • Check for line problems. • Replace the FCU or the NCU.
4-10	Communication failed because of an ID Code mismatch (Closed Network) or Tel. No./CSI mismatch (Protection against Wrong Connections)	<ul style="list-style-type: none"> • Get the ID Codes the same and/or the CSIs programmed correctly, then resend. • The machine at the other end may be defective.

Code	Meaning	Suggested Cause/Action
5-00	Data construction not possible	<ul style="list-style-type: none"> • Replace the FCU.
5-01	Data reconstruction not possible	
5-10	DCR timer expired	
5-20	Storage impossible because of a lack of memory	<ul style="list-style-type: none"> • Temporary memory shortage. • Test the SAF memory. • Replace the FCU or optional EXMEM board
5-21	Memory overflow	
5-22	Mode table overflow after the second page of a scanned document	<ul style="list-style-type: none"> • Wait for the messages which are currently in the memory to be sent or delete some files from memory.
5-23	Print data error when printing a substitute rx or confidential rx message	<ul style="list-style-type: none"> • Test the SAF memory. • Ask the other end to resend the message. • Replace the FCU or optional EXMEM board.
5-24	Memory overflow after the second page of a scanned document	<ul style="list-style-type: none"> • Try using a lower resolution setting. • Wait for the messages which are currently in the memory to be sent or delete some files from memory.
5-25	SAF file access error	<ul style="list-style-type: none"> • Replace the FCU or EXMEM board.
6-00	G3 ECM - T1 time out during reception of facsimile data	<ul style="list-style-type: none"> • Try adjusting the rx cable equalizer. • Replace the FCU or NCU.
6-01	G3 ECM - no V.21 signal was received	
6-02	G3 ECM - EOR was received	
6-04	G3 ECM - RTC not detected	<ul style="list-style-type: none"> • Check the line connection. • Check connections from the NCU to the FCU. • Check for a bad line or defective remote terminal. • Replace the FCU or NCU.
6-05	G3 ECM - facsimile data frame not received within 18 s of CFR, but there was no line fail	<ul style="list-style-type: none"> • Check the line connection. • Check connections from the NCU to the FCU. • Check for a bad line or defective remote terminal. • Replace the FCU or NCU. • Try adjusting the rx cable equalizer <p>Cross reference</p> <ul style="list-style-type: none"> • Rx cable equalizer - G3 Switch 07 (PSTN)
6-06	G3 ECM - coding/decoding error	<ul style="list-style-type: none"> • Defective FCU. • The other terminal may be defective.
6-08	G3 ECM - PIP/PIN received in reply to PPS.NULL	<ul style="list-style-type: none"> • The other end pressed Stop during communication. • The other terminal may be defective.
6-09	G3 ECM - ERR received	<ul style="list-style-type: none"> • Check for a noisy line. • Adjust the tx levels of the communicating machines. • See code 6-05.

Code	Meaning	Suggested Cause/Action
6-10	G3 ECM - error frames still received at the other end after all communication attempts at 2400 bps	<ul style="list-style-type: none"> • Check for line noise. • Adjust the tx level (use NCU parameter 01 or the dedicated tx parameter for that address). • Check the line connection. • Defective remote terminal.
6-21	V.21 flag detected during high speed modem communication	<ul style="list-style-type: none"> • The other terminal may be defective or incompatible.
6-22	The machine resets the sequence because of an abnormal handshake in the V.34 control channel	<ul style="list-style-type: none"> • Check for line noise. • If the same error occurs frequently, replace the FCU. • Defective remote terminal.
6-99	V.21 signal not stopped within 6 s	<ul style="list-style-type: none"> • Replace the FCU.
22-00	Original length exceeded the maximum scan length	<ul style="list-style-type: none"> • Divide the original into more than one page. • Check the resolution used for scanning. Lower the scan resolution if possible. • Add optional page memory.
22-01	Memory overflow while receiving	<ul style="list-style-type: none"> • Wait for the files in the queue to be sent. • Delete unnecessary files from memory. • Transfer the substitute reception files to an another fax machine, if the machine's printer is busy or out of order. • Add an optional SAF memory card or hard disk.
22-02	Tx or rx job stalled due to line disconnection at the other end	<ul style="list-style-type: none"> • The job started normally but did not finish normally; data may or may not have been received fully. • Restart the machine.
22-04	The machine cannot store received data in the SAF	<ul style="list-style-type: none"> • Update the ROM • Replace the FCU.
23-00	Data read timeout during construction	<ul style="list-style-type: none"> • Restart the machine. • Replace the FCU
25-00	The machine software resets itself after a fatal transmission error occurred	<ul style="list-style-type: none"> • Update the ROM • Replace the FCU.
F0-xx	V.34 modem error	<ul style="list-style-type: none"> • Replace the FCU.
F6-8x	SG3-V34 modem error	<ul style="list-style-type: none"> • Update the SG3-V34 modem ROM. • Replace the SG3-V34 board. • Check for line noise or other line problems. • Try communicating another V.8/V.34 fax.

3.2 ERROR CODES FOR THE ISDN OPTION

The tables on the following pages show the error codes for the ISDN option.

The meaning of the numbers in the Action column is as follows.

1. Check Layer 1 signaling with a protocol analyzer to determine the cause of the problem. This may require assistance from a G4 specialist.
2. Repeat the communication. If the problem does not repeat itself, the problem was a temporary one caused by the user connecting the machine to another interface. However, if the problem remains, there is a network problem.
3. There is a network problem.
4. There is a network problem. Do the following:
 - Check the error bit rate of the network. If it is high, contact the network and ask them to improve the line.
 - Check the network speed (is it 56 or 64 kbps), and make sure that the bit switch setting is correct. You may also use the dedicated transmission parameters if this problem only occurs when dialing certain numbers.
 - Check that the user dialed the correct number.
5. There is a network problem, or a problem in the machine at the other end.
6. There is a problem in the machine at the other end; ask a technician to check it.
7. The machine at the other end is not a Group 4 fax terminal.
8. The machine is not compatible with the machine at the other end. A compatibility test is needed.

Error codes related to the errors detected by the FCU are listed in the service manual of the main body.

3.2.1 D-CHANNEL LAYER MANAGEMENT

Code	Probable Cause	Action
7-00	Link reset	2
7-01	Link set-up failed because of time-out.	2
7-02	Link release failed because of time-out.	2
7-03	Link set-up parameter error	2

3.2.2 D-CHANNEL, LAYER 1

Code	Probable Cause	Action
7-10	T3 timeout (layer 1 activation error)	1
7-11	No connection on the S0 interface	1
7-12	Deactivated	1

3.2.3 D-CHANNEL LINK LAYER

Code	Probable Cause	Action
7-20	At the start of link set-up, the machine received an unsolicited S (F=1).	2
7-21	At the start of link set-up, the machine received an unsolicited DM (F=1).	2
7-22	At TEI release, the machine received an unsolicited UA (F=1).	2
7-23	At the start of link set-up, the machine received an unsolicited DM (F=0).	2
7-24	At TEI release, the machine received an unsolicited UA (F=0).	2
7-25	SABME received at the start of network link set-up	No error
7-26	N200 retransmission error for SABME	2
7-27	N200 retransmission error for DISC	2
7-28	N200 retransmission error for situation enquiry (RR)	2
7-29	N(R) sequence number error	3
7-30	N(S) sequence number error	3
7-31	FRMR received	3
7-32	Non-standard frame received	3
7-33	Abnormal frame length	3
7-34	N201 error; information field N in the I frame exceeded N201	3
7-35	T201 timeout; timeout while waiting for checking	3
7-36	T202 timeout; timeout while waiting for ID assignment	3

3.2.4 D-CHANNEL NETWORK LAYER

Code	Probable Cause	Action
7-40	Insufficient mandatory information elements	3
7-41	Abnormal LI for a mandatory information element	3
7-42	T301 timeout; timeout while waiting for R:CONN	3
7-43	T303 timeout; timeout while waiting for R: CALL-PROC etc.	3
7-44	T304 timeout; timeout while waiting for R: CALL-PROC etc.	3
7-45	T305 timeout; timeout while waiting for R:REL	3
7-46	T308 timeout; timeout while waiting for R:REL-COMP	3
7-47	T310 timeout; timeout while waiting for R: ALERT etc.	3
7-48	T313 timeout; timeout while waiting for R:CONN-ACK	3
7-49	Internal error	3
7-51	Release call reference during communication	3

3.2.5 B-CHANNEL LINK LAYER

Code	Probable Cause	Action
7-60	T3 timeout; timeout while waiting for flag	4
7-61	T3 timeout; timeout while waiting for SABM during an incoming call	4
7-62	T1 timeout x N2; timeout while waiting for UA after sending SABM	5
7-63	T1 timeout x N2; timeout while waiting for a response to a transmitted S frame (P=1)	5
7-64	T1 timeout x N2; timeout while waiting for SABM or DISC after sending FRMR	5
7-65	T1 timeout x N2; timeout while waiting for a response to DISC	5
7-66	RNR x N2 (other end busy, RCB counter error)	5
7-67	Invalid (Ad) frame received	5
7-68	Invalid short frame received	5
7-69	Link reset error	5
7-70	FRMR received	5
7-71	Non-standard (Cn) frame received	5
7-72	An S or U frame having an information field was received	5
7-73	A frame longer than the maximum N1 length was received	5
7-74	An S or I frame having an N(R) error was received	5
7-75	CRC error	3

3.2.6 B-CHANNEL NETWORK LAYER

Code	Probable Cause	Action
7-80	A packet having an abnormal GFI was received	6
7-81	A packet was received that had a logical channel number different from the logical channel being used for the communication	6
7-82	A packet containing a format error was received	6
7-83	A packet containing an LI error was received	7
7-84	A CN packet was received that had a PID different from 02	7
7-85	Unsupported packet type received	7
7-86	Abnormal or unsupported facility received	7
7-87	P(s) sequence number error	6
7-88	P(r) sequence number error	6
7-89	A reset using S:RQ or R:RI occurred	6
7-90	A restart using S:RQ or R:SI occurred	6
7-91	Call set-up error; in reply to S:CR, R:CI was received to indicate rejection of the call	7
7-92	T20 timeout; timeout while waiting for an SF packet	6
7-93	T21 timeout; timeout while waiting for a CC packet	6
7-94	T22 timeout; timeout while waiting for an RF packet	6
7-95	T23 timeout; timeout while waiting for a CF packet	6
7-96	T10 timeout; timeout while waiting for the first frame	6

3.2.7 TRANSPORT LAYER

Code	Probable Cause	Action
8-00	Invalid block received	8
8-01	TCC block received	8
8-02	TBR block received	8
8-05	TCR block; block format error	8
8-06	TCR block; block size parameter LI error	8
8-07	TCR block; extended addressing LI error	8
8-08	TCR block; block size length error	8
8-10	TCA block; block format error	8
8-11	TCA block; Tx origin reference data in TCR disagreed with the address reference data in TCA	8
8-12	TCA block; octet 7 did not equal 0	8
8-13	TCA block; extended addressing LI error	8
8-14	TCA block; block size exceeded that set by TCR	8
8-15	TCA block; block size parameter LI error	8
8-20	TDT block; block format error	8
8-21	TDT block; octet 3 did not equal either 00 or 80(H)	8
8-22	TDT block; the end indicator was "Continue" even though there was no field data	8
8-23	TDT block; an end block with no field data was received after an end indicator of "End"	8
8-26	Timeout during state 0.2	8
8-27	Timeout during state 1.1	8
8-28	Timeout during state 0.3	8

3.2.8 SESSION LAYER

Code	Probable Cause	Action
8-30	Invalid frame received	8
8-31	RSSN received	8
8-32	CSA received	8
8-34	Calling terminal identification error in CSS	8
8-35	Date and time error in CSS	8
8-36	Window size error in CSS	8
8-37	Service identification error in CSS	8
8-38	Session user data error in CSS	8
8-39	CSS rejected (new session rejected)	8
8-40	Called terminal identification error in RSSP	8
8-41	Date and time error in RSSP	8
8-42	Date and time in RSSP was not the same as that in CSS	8
8-43	Window size error in RSSP	8
8-44	Service identification error in RSSP	8
8-45	Session user data error in RSSP	8
8-47	Message synchronization error inside the CCU	8
8-48	Document task busy	8
8-50	Ti timeout; non-communication surveillance timer (T.62)	8
8-51	T2 timeout; timeout while waiting for a response (T.62)	8
8-52	T3 timeout; CSA timer timeout (T.62)	8
8-53	G4 board load timer timeout; calling side waited too long for a new session	8
8-54	G4 board load timer timeout; calling side waited too long for transport probability	8
8-55	G4 board load timer timeout; called side waited too long for S:RSSP	8
8-56	G4 board load timer timeout; document transmission surveillance timer timeout	8
8-57	G4 board load timer timeout; timeout while waiting for a user abort request after a provider fail	8

 A vertical black rectangular box containing the text "Trouble-shooting" in white, oriented vertically.

3.2.9 DOCUMENT LAYER

Code	Probable Cause	Action
8-60	T.62 coding format error (LI error)	8
8-61	A mandatory PI was absent, or the LI for a mandatory PI was 0	8
8-62	Calling/called terminal identification LI was different from that specified by F.184 (LI = 24)	8
8-63	The LI for session user data exceeded the maximum value (512)	8
8-64	The LI for CDUI was not 0	8
8-65	Checkpoint and document reference numbers LI error, or they were not in T.61 (ASCII) coding	8
8-66	The checkpoint reference number differed from the expected value	8
8-70	RDGR received	8
8-71	A non-standard PDU was received while in calling mode	8
8-72	A non-standard PDU was received while in called mode	8
8-73	Abnormal PDU received while in calling state ds1	8
8-74	15 consecutive CDCL signals received	8
8-75	Session window size control error (size not equal to 0)	8
8-76	Internal error	8

3.2.10 PRESENTATION LAYER

Code	Probable Cause	Action
8-80	X.209 coding error in session user data (LI error)	8
8-81	PV error in session user data	8
8-82	PI error in session user data	8
8-83	The capabilities in the session user data of CDS/CDC were not the same as those in RDCLP	8
8-84	X.209 coding error in the DP (LI error)	8
8-85	X.209 coding error in the SLD (document descriptor/page descriptor) (LI error)	8
8-86	SLD object type absent	8
8-87	PI error in the SLD (document descriptor/page descriptor)	8
8-88	The capabilities in the SLD (document descriptor/page descriptor) are duplicated or are not the same as those in RDCLP	8
8-89	No document descriptor at the start of the document	8
8-90	No page descriptor at the start of the page	8
8-91	Page descriptor PV error	8
8-92	X.209 coding error in the TU (LI error)	8
8-93	The TU was absent	8
8-94	PV error in the TU	8
8-95	TI error	8
8-96	X.209 coding nest level >> 8, or an LI form error	8
8-97	CDPB/CDE received while TU/TI not yet completed, or an unexpected PDU was received while analyzing an SLD	8

3.3 FAX SC CODES

3.3.1 OVERVIEW

When the FCU detects a Fax SC Code condition other than SC1201 and SC1207, it resets itself automatically (default setting). This initializes the FCU without erasing files in the SAF memory or resetting the switches.

NOTE: For details on Fax SC Codes 1201 and 1207, refer to the following sections.

If bit 7 of System Switch 1F is changed to “1”, when the FCU detects a Fax SC Code condition, it displays the code on the display and stops working until the fax unit is initialized using one of the following methods:

- Hold down the “7” and “9” keys for more than 10 s.
- Turn off the main power switch and turn it back on.

3.3.2 SC1201

When the FCU detects an unrecoverable error in the SRAM, which requires a complete SRAM initialization, the fax unit displays this SC Code and stops. There is no way to recover from this error condition without a complete SRAM initialization (all the user and service programmed data will be erased).

The possible causes are:

- SRAM backup battery defect, or SW1 on the MBU is at the “OFF” position
- The SRAM on the MBU has a physical defect
- Flash memory card connection was loose

3.3.3 SC1207

This is the same as SC1201 except the error location is the SRAM on the Fax Function Upgrade board.

The possible causes are:

- SRAM backup battery defect, or SW1 on the Fax Function Upgrade board is at the “OFF” position.
- SRAM on the Fax Function Upgrade board has a physical defect.
- The Fax Function Upgrade board connection was loose.

3.3.4 FAX SC CODE TABLE

SC Code	Description	Suggested Action	Sys Switch 1F bit 7 = 0	Sys Switch 1F bit 7 = 1
1001	FCU error	Initialize the fax unit. (See section 2.3.1. for the initialization procedure)	Automatic reset	SC Code display
1201	Unrecoverable FCU - SRAM error	Refer to section 2.3.2.	"Service Call" display	
1207	Unrecoverable Fax Function Upgrade - SRAM error	Refer to section 2.3.3.	"Service Call" display	
1299	Software error	Initialize the fax unit.	Automatic reset	
1305				
1310				
1311				
1312				
1401				
1405				

3.4 ISDN TEST FUNCTION

3.4.1 LEDS

There are four LEDs on the G4 board. These LEDs describe the status of the machine.

LED 1	LED 2	LED 3	LED 4
-------	-------	-------	-------

Initial Settings

Initial check (if the flash ROM is updated)

O=ON, --=OFF

O	O	O	O
---	---	---	---

Handshaking with the FCU ready

O	O	--	--
---	---	----	----

Standby Mode

Ready to communicate

--	--	--	--
----	----	----	----

Communication

Layer 1 activated

--	--	--	O
----	----	----	---

Link setup

--	--	O	O
----	----	---	---

B channel 1 connected

--	O	O	O
----	---	---	---

B channel 2 connected

O	--	O	O
---	----	---	---

Trouble-shooting

3.4.2 BACK-TO-BACK TEST

To make a back-to-back test, you need:

- Two machines, one with the CiG4 board (G4 board used in the FX4, FR4, ADAM, NAD, Stinger, and Russian) and the other with the SiG4 board (G4 board used with the Schmidt 3, S4, and Kaiser 1).
- Cross rosette

NOTE: You cannot make a back-to-back test using two SiG4 machines.

The procedure is as follows.

1. Switch off the machines
2. Connect two machines back-to-back using a cross rosette as follows.

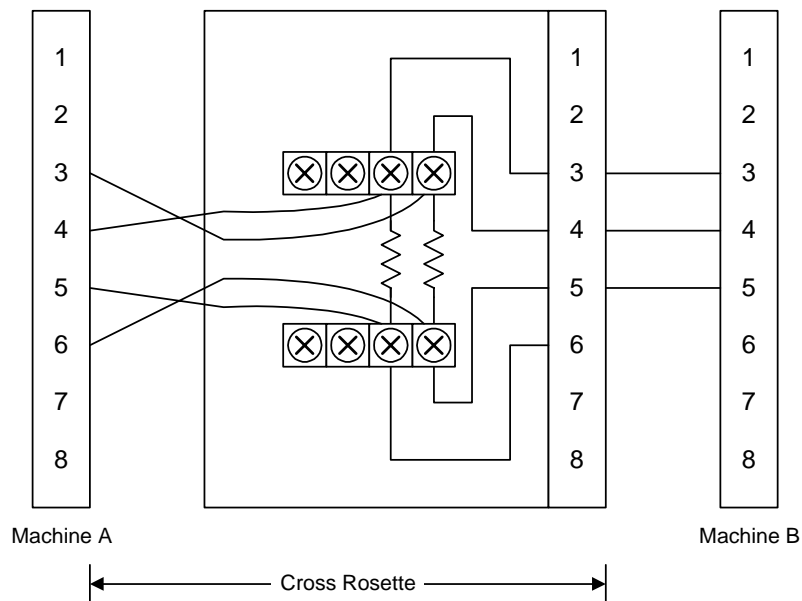

B502T601.WMF

3. Make the following bit switch adjustments:
 - In the machine acting in NT mode (CiG4 board), set bits 0 and 1 of G4 parameter switch 0D to 1.
 - In the machine acting in TE mode (SiG4 board) set bit 0 of G4 parameter switch 0D to 0 and bit 1 to 1.
4. Reset the machines by switching them off, waiting a few seconds, then switching back on.
5. Place a document in one of the machines, dial a number, then press Start.
6. After you have finished the test, set bits 0 and 1 of G4 parameter switch 0D back to 0, then reset the machine.

NOTE: The following cannot be tested using this procedure:

- ISDN G3 communication
- Point to Multi (Like a broadcasting test, from one point to many places.)

4. SERVICE TABLES

CAUTION

Never turn off the main power switch when the power LED is lit or flashing. To avoid damaging the hard disk or memory, press the operation power switch to switch the power off, wait for the power LED to go off, and then switch the main power switch off.



NOTE: The main power LED () lights or flashes while the platen cover or ARDF is open, while the main machine is communicating with a facsimile or the network server, or while the machine is accessing the hard disk or memory for reading or writing data.

4.1 SERVICE PROGRAM MODE

4.1.1 SERVICE PROGRAM MODE OPERATION

The service program (SP) mode is used to check electrical data, change modes, and adjust values.

Entering and Exiting SP Mode

- | | |
|---|---|
|  | 1. Press the Clear Mode key. |
|  | 2. Use the keypad to enter "107". |
|  | 3. Hold down Clear/Stop for at least 3 seconds. |
| Fax SP | 4. On the touch-panel, press Fax SP. |
| Exit | 5. Press Exit twice to return to the copy window. |

SP Mode Button Summary

Here is a short summary of the touch-panel buttons.

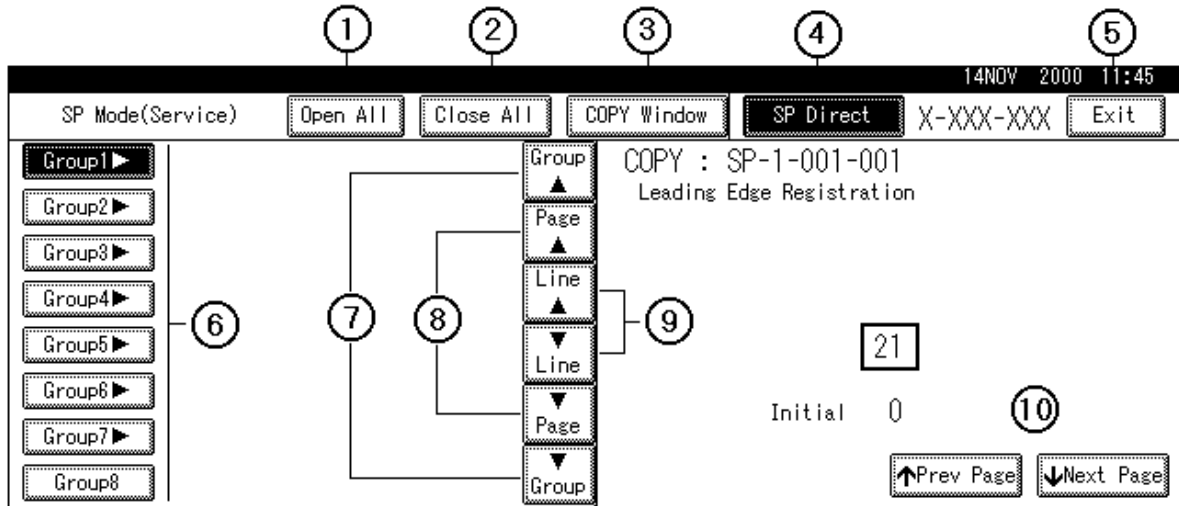

B502S500.WMF

- ① Opens all SP groups and sublevels.
- ② Closes all open groups and sublevels and restores the initial SP mode display.
- ③ Not used for the Fax SP mode.
- ④ Enter the SP mode directly with the number keys if you know the SP number and then press $\#$. (SP Mode must be highlighted before you can enter the number. Just press SP Mode if it is not highlighted.)
- ⑤ Press twice to leave the SP mode return to the copy window to resume normal operation.
- ⑥ Press any Group number to open a list of SP modes and titles for that group. For example, to open the SP mode list for SP1-nnn , press Group1. If an SP has sublevels, click the appropriate button to expand the list.
- ⑦ Press to scroll the display to the previous or next group.
- ⑧ Press to scroll to the previous or next display in segments the size of the screen display (page).
- ⑨ Press to scroll the display to the previous or next line, line by line.
- ⑩ Press to move to the highlight to the previous or next selection in the list on the left.

Switching Between SP Mode and Copy Mode for Test Printing

- 1) In the SP mode, select the test print and then press Copy Window.
- 2) Use the copy window (copier mode), to select the appropriate settings (paper size, etc.) for the test print.
- 3) Press Start (Ⓢ) to execute the test print.
- 4) Press SP Mode (highlighted) to return to the SP mode screen and repeat from step 1.

Selecting the Program Number

Program numbers have two or three levels.

1. Before you begin, refer to the Service Tables to find the SP that you want to adjust. (☛ 4.1.2)
2. Click the Group number on the left side SP Mode window that contains the SP that you want to adjust.
3. Use the scrolling buttons in the center of the SP mode window to display the SP number that you want to open, and then press that number to expand the list.
4. Use the center touch-panel buttons to scroll to the number and title of the item that you want to set and press. The small entry box on the right is activated and displays the default or the current setting below.

Service Tables

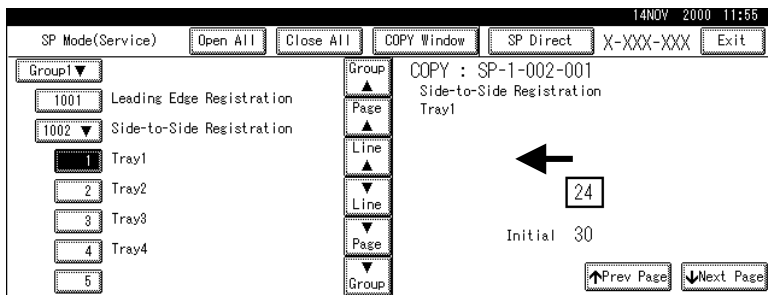









B502S501.WMF

NOTE: Refer to the Service Tables for the range of allowed settings. (☛ 4.1.2)



1. To enter a setting
 - Press (+/-) to toggle between plus and minus and then use the keypad to enter the appropriate number. The number you enter write over the previous setting.
 - Press (#) to enter the setting. (If you enter a number that is out of range, the key press is ignored.)
 - When you are prompted to complete the selection, press Yes.
2. When you are finished, press Exit twice to return to the copy window.

4.1.2 SERVICE PROGRAM MODE TABLES

SP1-XXX (Bit Switches) Section 3.2 Bit Switches

1	Mode No.		Function
101	System Switch		Change the bit switches for system settings for the fax option  Section 3.2 Bit Switches
	001 – 032	00 – 1F	
102	Scanner Switch		Change the bit switches for scanner settings for the fax option  Section 3.2 Bit Switches
	001 – 016	00 – 0F	
103	Printer Switch		Change the bit switches for printer settings for the fax option  Section 3.2 Bit Switches
	001 – 016	00 – 0F	
104	Communication Switch		Change the bit switches for communication settings for the fax option  Section 3.2 Bit Switches
	001 – 032	00 – 1F	
105	G3-1 Switch		Change the bit switches for the protocol settings of the standard G3 board  Section 3.2 Bit Switches
	001 – 016	00 – 0F	
106	G3-2 Switch		Change the bit switches for the protocol settings of the optional G3 board  Section 3.2 Bit Switches
	001 – 016	00 – 0F	
108	G4 Internal Switch		Change the bit switches for the optional ISDN settings  Section 3.2 Bit Switches
	001 – 032	00 – 1F	
109	G4 Parameter Switch		Change the bit switches for optional ISDN parameters  Section 3.2 Bit Switches
	001 – 016	00 – 0F	

SP2-XXX (RAM Data)

2	Mode No.		Function
101	RAM Read/Write		Change RAM data for the fax board directly.  Section 3.5 Service RAM Addresses
	001		
102	Memory Dump		Print out RAM data for the fax board.  Section 3.5 Service RAM Addresses
	001	G3-1 Memory Dump	
	002	G3-2 Memory Dump	
	004	G4 Memory Dump	

2	Mode No.		Function
103	G3-1 NCU Parameters		
	001 – 023	CC, 01 – 22	NCU parameter settings for the standard G3 board. ➔ Section 3.3 NCU Parameters
104	G3-2 NCU Parameters		
	001 – 023	CC, 01 – 22	NCU parameter settings for the optional G3 board. ➔ Section 3.3 NCU Parameters

SP3-XXX (Tel Line Settings)

3	Mode No.		Function
101	Service Station		
	001	Fax Number	Enter the fax number of the service station.
	002	Select Line	Select the line type.
102	Serial Number		
	000		Enter the fax unit's serial number.
103	PSTN-1 Port Settings		
	001	Select Line	Select the line type setting for the G3-1 line. If the machine is installed on a PABX line, select "PABX", "PABX(GND)" or "PABX(FLASH)".
	002	PSTN Access Number	Enter the PSTN access number for the G3-1 line.
	003	Memory Lock Disabled	If the customer does not want to receive transmissions using Memory Lock on this line, turn this SP on.
	004	Transmission Disabled	If you turn this SP on, the machine does not send any fax messages on the G3-1 line.
104	PSTN-2 Port Settings		
	001	Select Line	Select the line setting for the G3-2 line. If the machine is installed on a PABX line, select "PABX", "PABX(GND)" or "PABX(FLASH)".
	002	PSTN Access Number	Enter the PSTN access number for the G3-2 line.
	003	Memory Lock Disabled	If the customer does not want to receive transmissions using Memory Lock on this line, change this SP to on.
	004	Transmission Disabled	If you turn this SP on, the machine does not send any fax messages on the G3-2 line.
106	ISDN Port Settings		
	001	Select Line	Select the line setting for the ISDN line. If the machine is installed to the PABX line, select "PABX".
	002	PSTN Access Number	Enter the PSTN access number for ISDN line.
	003	Memory Lock Disabled	If the customer does not want to receive transmissions using Memory Lock on this line, change this SP to on
	004	Transmission Disabled	If you turn this SP on, the machine does not send any fax messages on the ISDN line.

SP4-XXX (ROM Versions)

4	Mode No.		Function
101	001	FCU ROM Version	Displays the FCU ROM version.
102	001	Error Codes	Displays the latest 64 fax error codes.
103	001	G3-1 ROM Version	Displays the G3-1 modem version.
104	001	G3-2 ROM Version	Displays the G3-2 modem version.
106	001	G4 ROM Version	Displays the G4 (ISDN) ROM version.
107	001	Charge ROM Version	Not used.

SP5-XXX (Initializing)

5	Mode No.		Function
101	Initialize SRAM		Initializes the bit switches and user parameters, user data in the SRAM, files in the SAF memory, and clock.
	000		
102	Erase All Files		Erases all files stored in the SAF memory.
	000		
103	Reset Bit Switches		Resets the bit switches and user parameters.
	000		
104	Factory setting		Resets the bit switches and user parameters, user data in the SRAM and files in the SAF memory.
	000		
105	Delete All Speed Dials		200 speed dials and 1000 quick dials are available when the Fax Function Upgrade Unit is installed.
	001	Speed Dials Enabled	
	002	Speed Dials Disabled	

SP6-XXX (Reports)

6	Mode No.		Function
101	System Parameter List		Touch the "ON" button to print the system parameter list.
	000		
102	Service Monitor Report		Touch the "ON" button to print the service monitor report.
	000		
103	G3 Protocol Dump List		Prints the protocol dump list of all communications for all G3 lines.
	001	G3 All Communications	
	002	G3-1 (All Communications)	

6	Mode No.		Function
103	003	G3-1 (1 Communication)	Prints the protocol dump list of the last communication for the G3-1 line.
	004	G3-2 (All Communications)	Prints the protocol dump list of all communications for the G3-2 line.
	005	G3-2 (1 Communication)	Prints the protocol dump list of the last communication for the G3-2 line.
104	G4 Protocol Dump List		
	001	Dch + Bch 1	Prints the protocol dump lists for the G4 line.
	002	Dch	
	003	Bch 1 Link Layer	
	004	Dch Link Layer	
	005	Dch +Bch 2	
	006	Bch 2 Link Layer	
105	All Files print out		
	000		Prints out all the user files in the SAF memory, including confidential messages. NOTE: Do not use this function, unless the customer is having trouble printing confidential messages or recovering files stored using the memory lock feature.
106	Journal Print out		
	001	All Journals	The machine prints all the communication records on the report.
	002	Specified Date	The machine prints all communication records after the specified date.
107	Log List Print out		
	001	All log files	These log print out functions are for designer use only.
	002	Printer	
	003	SC/TRAP Stored	
	004	Decompression	
	005	Scanner	
	006	JOB/SAF	
	007	Reconstruction	
	008	JBIG	
	009	Fax Driver	
	010	G3CCU	
	011	Fax Job	
	012	CCU	
	013	Scanner Condition	

SP7-XXX (Test Modes)

These are the test modes for PTT approval.

7	Function
101	G3-1 Modem Tests
102	G3-1 DTMF Tests
103	Ringer Test
104	G3-1 V34 (S2400baud)
105	G3-1 V34 (S2800baud)
106	G3-1 V34 (S3000baud)
107	G3-1 V34 (S3200baud)
108	G3-1 V34 (S3429baud)
109	Recorded Message Test
110	G3-2 Modem Tests
111	G3-2 DTMF Tests
112	G3-2 V34 (S2400baud)
113	G3-2 V34 (S2800baud)
114	G3-2 V34 (S3000baud)
115	G3-2 V34 (S3200baud)
116	G3-2 V34 (S3429baud)
124	IG3-1 Modem Tests
125	IG3-1 DTMF Tests
126	IG3-1 V34 (S2400baud)
127	IG3-1 V34 (S2800baud)
128	IG3-1 V34 (S3000baud)
129	IG3-1 V34 (S3200baud)
130	IG3-1 V34 (S3429baud)
131	IG3-2 Modem Tests
132	IG3-2 DTMF Tests
133	IG3-2 V34 (S2400baud)
134	IG3-2 V34 (S2800baud)
135	IG3-2 V34 (S3000baud)
136	IG3-2 V34 (S3200baud)
137	IG3-2 V34 (S3429baud)

4.2 BIT SWITCHES

⚠ WARNING

Do not adjust a bit switch or use a setting that is described as “Not used”, as this may cause the machine to malfunction or to operate in a manner that is not accepted by local regulations. Such bits are for use only in other areas, such as Japan.

NOTE: Default settings for bit switches are not listed in this manual. Refer to the System Parameter List printed by the machine.

4.2.1 SYSTEM SWITCHES

System Switch 00		SP No. 1-101-001
No	FUNCTION	COMMENTS
0	Dedicated transmission parameter programming 0: Disabled 1: Enabled	Set this bit to 1 before changing any dedicated transmission parameters. Reset this bit to 0 after programming dedicated transmission parameters.
1	Confidential RX message print out without the password. 0: Disabled 1: Enabled	1: Confidential RX messages can be printed out without the password. Use this bit if the customer forgot the password for the confidential messages. Reset this bit to 0 after printing confidential RX messages.
2	Technical data printout on the Journal 0: Disabled 1: Enabled	1: Instead of the personal name, the following data are listed on the Journal for each G3 communication.
<p>e.g. 0000 32V34 288/264 L0100 03 04 (1) (2)(3) (4) (5) (6) (7) (8)</p> <p>(1): EQM value (Line quality data). A larger number means more errors. (2): Symbol rate (V.34 only) (3): Final modem type used (4): Starting data rate (for example, 288 means 28.8 kbps) (5): Final data rate (6): Rx revel (refer to the note after this table for how to read the rx level) (7): Total number of error lines that occurred during non-ECM reception. (8): Total number of burst error lines that occurred during non-ECM reception.</p> <p>Note: EQM and rx level are fixed at “FFFF” in tx mode. The seventh and eighth numbers are fixed at “00” for transmission records and ECM reception records.</p>		

Service Tables

System Switch 00		SP No. 1-101-001
No	FUNCTION	COMMENTS
2	<p>Rx level calculation</p> <p>Example: 0000 32 V34 288/264 L <u>01 00</u> 03 04</p> <p>The four-digit hexadecimal value (N) after "L" indicates the rx level. The <u>high</u> byte is given first, followed by the <u>low</u> byte. Divide the decimal value of N by -16 to get the rx level.</p> <p>In the above example, the decimal value of N (= 0100 [H]) is 256. So, the actual rx level is 256/-16 = -16 dB</p>	
3-4	Not used	Do not change the settings.
5	<p>G3/G4 communication parameter display</p> <p>0: Disabled 1: Enabled</p>	<p>This is a fault-finding aid. The LCD shows the key parameters (see below). This is normally disabled because it cancels the CSI display for the user. Be sure to reset this bit to 0 after testing.</p>
6	<p>Protocol dump list output after each communication</p> <p>0: Off 1: On</p>	<p>This is only used for communication troubleshooting. It shows the content of the transmitted facsimile protocol signals. Always reset this bit to 0 after finishing testing. If system switch 09 bit 6 is at "1", the list is only printed if there was an error during the communication.</p>
7	Not used	Do not change the setting.

G3 Communication Parameters

Modem rate	<p>336: 33600 bps 168: 16800 bps 312: 31200 bps 144: 14400 bps 288: 28800 bps 120: 12000 bps 264: 26400 bps 96: 9600 bps 240: 24000 bps 72: 7200 bps 216: 21600 bps 48: 4800 bps 192: 19200 bps 24: 2400 bps</p>
Resolution	<p>S: Standard (8 x 3.85 dots/mm) D: Detail (8 x 7.7 dots/mm) F: Fine (8 x 15.4 dots/mm) SF: Superfine (16 x 15.4 dots/mm) 21: Standard (200 x 100 dpi) 22: Detail (200 x 200 dpi) 44: Superfine (400 x 400 dpi)</p>
Compression mode	<p>MMR: MMR compression MR: MR compression MH: MH compression JBO: JBIG compression (Optional mode) JBB: JBIG compression (Basic mode)</p>
Communication mode	<p>ECM: With ECM NML: With no ECM</p>
Width and reduction	<p>A4: A4 (8.3"), no reduction B4: B4 (10.1"), no reduction A3: A3 (11.7"), no reduction</p>

I/O rate	0: 0 ms/line 10: 10 ms/line 25: 2.5 ms/line 20: 20 ms/line 5: 5 ms/line 40: 40 ms/line Note: "40" is displayed while receiving a fax message using AI short protocol.
----------	---

G4 Communication Parameters

Compression mode	MMR: MMR compression MR: MR compression MH: MH compression
Resolution	21: Standard (200 x 100 dpi) 22: Detail (200 x 200 dpi) 44: Superfine (400 x 400 dpi)
Width and reduction	A4: A4 (8.3"), no reduction B4: B4 (10.1"), no reduction A3: A3 (11.7"), no reduction
Transfer	T: Transfer - : Other
Confidential	C: Confidential - : Other
Other parameters	The following information is shown in 6-bit format. Bit 1 is the first bit from the left, and bit 6 is at the right end. Bit 1 - Smoothing 0: Off, 1: On (Smoothing is disabled in halftone mode.) Bit 2 - CIL printing 0: On, 1: Off Bit 3 - Not used Bit 4 - mm/inch conversion 0: Off, 1: On Bit 5 - Engine type 0: mm, 1: inches Bit 6 - Document resolution unit 0: mm, 1: inches

Service Tables

System Switch 01 - Not used (Do not change the factory settings.)

System Switch 02		SP No. 1-101-003
No	FUNCTION	COMMENTS
0-3	Not used	Do not change the settings.
4	File retention time 0: Depends on User Parameter 24 [18(H)] 1: No limit	1: A file that had a communication error will not be erased unless the communication is successful.
5	Not used	Do not change the settings.

System Switch 02		SP No. 1-101-003
No	FUNCTION	COMMENTS
6	Memory read/write by RDS	<p>(0,0): All RDS systems are always locked out.</p> <p>(0,1), (1,0): Normally, RDS systems are locked out, but the user can temporarily switch RDS on to allow RDS operations to take place. RDS will automatically be locked out again after a certain time, which is stored in System Switch 03. Note that if an RDS operation takes place, RDS will not switch off until this time limit has expired.</p> <p>(1,1): At any time, an RDS system can access the machine.</p>
7	Bit 7 6 Setting	
	0 0 Always disabled	
	0 1 User selectable	
	1 0 User selectable	
	1 1 Always enabled	

System Switch 03		SP No. 1-101-004
No	FUNCTION	COMMENTS
0 to 7	Length of time that RDS is temporarily switched on when bits 6 and 7 of System Switch 02 are set to "User selectable"	<p>00 - 99 hours (BCD).</p> <p>This setting is only valid if bits 6 and 7 of System Switch 02 are set to "User selectable". The default setting is 24 hours.</p>

System Switch 04		SP No. 1-101-005
No	FUNCTION	COMMENTS
0-2	Not used	Do not change the settings.
3	<p>Printing dedicated tx parameters on Quick/Speed Dial Lists</p> <p>0: Disabled</p> <p>1: Enabled</p>	<p>1: Each Quick/Speed dial number on the list is printed with the dedicated tx parameters (10 bytes each).</p> <p>The first 10 bytes of data are the programmed dedicated tx parameters; 34 bytes of data are printed (the other 24 bytes have no use for service technicians).</p>
4-7	Not used	Do not change the settings.

System Switch 05 - Not used (Do not change the factory settings.)

System Switch 06		SP No. 1-101-007
No	FUNCTION	COMMENTS
0 to 7	Margin setting for Create Margin Transmission	<p>71 to 99 (BCD) %. This setting determines the reduction ratio when the user uses the Create Margin Transmission feature.</p> <p>Default setting:1001 0011 (93%)</p>

System Switch 07 - Not used (Do not change the factory settings.)

System Switch 08 - Not used (Do not change the factory settings.)

System Switch 09		SP No. 1-101-010
No	FUNCTION	COMMENTS
0	Addition of image data from confidential transmissions on the transmission result report 0: Disabled 1: Enabled	If this feature is enabled, the top half of the first page of confidential messages will be printed on transmission result reports.
1	Inclusion of communications on the Journal when no image data was exchanged. 0: Disabled 1: Enabled	0: Communications that reached phase C (message tx/rx) of the T.30 protocol are listed on the Journal. 1: Communications that reached phase A (call setup) of T.30 protocol are listed on the Journal. This will include telephone calls.
2	Automatic error report printout 0: Disabled 1: Enabled	0: Error reports will not be printed. 1: Error reports will be printed automatically after failed communications.
3	Printing of the error code on the error report 0: No 1: Yes	1: Error codes are printed on the error reports.
4	Not used	Do not change the settings.
5	Power failure report 0: Disabled 1: Enabled	1: A power failure report will be automatically printed after the power is switched on if a fax message disappeared from the memory when the power was turned off last.
6	Conditions for printing the protocol dump list 0: Print for all communications 1: Print only when there is a communication error	This switch becomes effective only when system switch 00 bit 6 is set to 1. 1: Set this bit to 1 when you wish to print a protocol dump list only for communications with errors.
7	Priority given to various types of remote terminal ID when printing reports 0: RTI > CSI > Dial label > Tel. number 1: Dial label > Tel. number > RTI > CSI	This bit determines which set of priorities the machine uses when listing remote terminal names on reports. In G4 communication, G4_TID (Terminal ID) is used instead of RTI or CSI. Dial Label: The name stored, by the user, for the Quick/Speed Dial number.

System Switch 0A		SP No. 1-101-011
No	FUNCTION	COMMENTS
0-2	Not used	Do not change the settings.
3	Continuous polling reception 0: Disabled 1: Enabled	This feature allows a series of stations to be polled in a continuous cycle. This will continue until the polling reception file is erased. The dialing interval is the same as memory transmission.
4	Dialing on the ten-key pad when the external telephone is off-hook 0: Disabled 1: Enabled	0: Prevents dialing from the ten-key pad while the external telephone is off-hook. Use this setting when the external telephone is not by the machine, or if a wireless telephone is connected as an external telephone. 1: The user can dial on the machine's ten-key pad when the handset is off-hook.
5	On hook dial 0: Disabled 1: Enabled	0: On hook dial is disabled.
6	Line used for G3 transmission 0: PSTN 1: ISDN	If an ISDN unit has been installed, this bit determines whether G3 transmissions go out over the PSTN or the ISDN.
7	Line used when the machine falls back to G3 from G4 if the other end is not a G4 machine 0: PSTN 1: ISDN	This bit switch has no effect if Communication Switch 07 bit 0 is set to 0.

System Switch 0B - Not used (Do not change the factory settings.)
System Switch 0C - Not used (Do not change the factory settings.)
System Switch 0D - Not used (Do not change the factory settings.)

System Switch 0E		SP No. 1-101-015
No	FUNCTION	COMMENTS
0-2	Not used	Do not change the settings.
3	Action when the external handset goes off-hook 0: Manual tx and rx operation 1: Memory tx and rx operation (the display remains the same)	0: Manual tx and rx are possible while the external handset is off-hook. However, memory tx is not possible. 1: The display stays in standby mode even when the external handset is used, so that other people can use the machine for memory tx operation. Note that manual tx and rx are not possible with this setting.
4-7	Not used	Do not change the settings.

System Switch 0F		SP No. 1-101-016
No	FUNCTION	COMMENTS
0 to 7	Country/area code for functional settings (Hex) 00: France 11: USA 01: Germany 12: Asia 02: UK 13: Japan 03: Italy 14: Hong Kong 04: Austria 15: South Africa 05: Belgium 16: Australia 06: Denmark 17: New Zealand 07: Finland 18: Singapore 08: Ireland 19: Malaysia 09: Norway 1A: China 0A: Sweden 1B: Taiwan 0B: Switz. 1C: Korea 0C: Portugal 20: Turkey 0D: Holland 21: Greece 0E: Spain 22: Hungary 0F: Israel 23: Czech 10: Canada 24: Poland	This country/area code determines the factory settings of bit switches and RAM addresses. However, it has no effect on the NCU parameter settings and communication parameter RAM addresses. Cross reference NCU country code: SP No. 2-103-001 for G3-1 SP No. 2-104-001 for G3-2

Service Tables

System Switch 10		SP No. 1-101-017
No	FUNCTION	COMMENTS
0 to 7	Threshold memory level for parallel memory transmission	Threshold = N x 128 KB + 256 KB N can be between 00 - FF(H) Default setting: 02(H) = 512 KB

System Switch 11		SP No. 1-101-018
No	FUNCTION	COMMENTS
0	TTI printing position 0 : Superimposed on the page data 1 : Printed before the data leading edge	Change this bit to 1 if the TTI overprints information that the customer considers to be important (G3 transmissions).
1	TSI (G3) or CIL/TID (G4) printing position 0 : Superimposed on the page data 1 : Printed before the data leading edge	Change this bit to 1 if the TSI (G3) or CIL/TID (G4) overprints information that the customer considers to be important. CIL: Command Information Line (Group 4)
2	Not used	Do not change the factory settings.
3	TTI used for broadcasting 0 : The TTIs selected for each Quick/Speed dial are used 1 : The same TTI is used for all destinations	1 : The TTI (TTI_1 or TTI_2) which is selected for all destinations during broadcasting.

System Switch 11		SP No. 1-101-018
No	FUNCTION	COMMENTS
4	Type of TTI used for transmission using the ten-key pad 0: TTI_1 1: TTI_2	1: The machine uses TTI_2 when the user dials the destination using the ten-key pad. It is also used for polling transmission and manual transmission using the handset.
5-6	Not used	Do not change the factory settings.
7	Use of parallel memory transmission with G4 transmission 0: Disabled 1: Enabled	This determines whether parallel transmission can be used with a G4 transmission or not. Note that this bit is only effective if Parallel Memory transmission is enabled (User Parameter 07 - bit 2).

System Switch 12		SP No. 1-101-019
No	FUNCTION	COMMENTS
0 to 7	TTI/CIL printing position in the main scan direction	TTI/CIL: 08 to 92 (BCD) mm Input even numbers only. This setting determines the print start position for the TTI and CIL from the left edge of the paper. If the TTI is moved too far to the right, it may overwrite the file number which is on the top right of the page. On an A4 page, if the CIL is moved over by more than 50 mm, it may overwrite the page number.

System Switch 13 - Not used (do not change the settings)
System Switch 14 - Not used (do not change the settings)

System Switch 15		SP No. 1-101-022
No	FUNCTION	COMMENTS
0	Not used	Do not change the settings.
1	Going into the Energy Saver mode automatically 0: Enabled 1: Disabled	1: The machine will restart from the Energy Saver mode quickly, because the +5V power supply is active even in the Energy Saver mode.
2-3	Not used	Do not change the settings.
4-5	Interval for preventing the machine from entering Energy Saver mode if there is a pending transmission file. Bit 5 4 Setting 0 0 1 min 0 1 30 min 1 0 1 hour 1 1 24 hours	If there is a file waiting for transmission, the machine does not go to Energy Saver mode during the selected period. After transmitting the file, if there is no file waiting for transmission, the machine goes to the Energy Saver mode.
6	Print user codes on reports. 0: Disabled 1: Enabled	1: User codes are printed out on the Journal or other reports.
7	Not used	Do not change the settings.

System Switch 16		SP No. 1-101-023
No	FUNCTION	COMMENTS
0	Parallel Broadcasting 0: Disabled 1: Enabled	1: When the G4 or/and G3 unit is installed, the machine sends messages simultaneously using both available ports (PSTN/ISDN) during broadcasting.
1	Priority setting for the G3 line. 0: PSTN-1 > PSTN-2 1: PSTN-2 > PSTN-1	This function allows the user to select the default G3 line type. The optional SG3 unit is required to use the PSTN-2 setting.
2	Changing the I-G3 modem default. 0: PSTN-1 1: PSTN-2	This function allows the user to select the default I-G3 modem. The optional SG3 unit and ISDN unit are required to use the PSTN-2 setting.
3	Line used for I-G3 transmissions 0: Allowed to change 1: Fixed	0: The machine will place priority on the line selected by the above bit 2 for I-G3 transmissions. 1: The machine will always use the line selected by the above bit 2 for I-G3 transmissions.
4-7	Not used	Do not change the settings.

System Switch 17 - Not used (do not change the settings)

System Switch 18 - Not used (do not change the settings)

Service
Tables



System Switch 19		SP No. 1-101-026
No	FUNCTION	COMMENTS
0-5	Not used	Do not change the settings.
6	Extended scanner page memory after memory option is installed 0: Disabled 1: Enabled	0: After installing the memory expansion option, the scanner page memory is extended to 4 MB from 2 MB. 1: If this bit is set to 1 after installing the memory expansion option, the scanner page memory is extended to 12 MB. But the SAF memory decreases to 18 MB.
7	Special Original mode 0: Disabled 1: Enabled	1: If the customer frequently wishes to transmit a form or letterhead which has a colored or printed background, change this bit to "1". "Original 1" and "Original 2" can be selected in addition to the "Text", "Text/Photo" and "Photo" modes.

System Switch 1A - Not used (do not change the settings)

System Switch 1B - Not used (do not change the settings)

System Switch 1C - Not used (do not change the settings)

System Switch 1D		SP No. 1-101-030
No	FUNCTION	COMMENTS
0	RTI/CSI/CPS display 0: Disabled 1: Enabled	1: RTI/CSI/CPS is displayed on the top line of the LCD panel during communication.
1-7	Not used	Do not change the settings.

System Switch 1E		SP No. 1-101-031
No	FUNCTION	COMMENTS
0	Communication after the Journal data storage area has become full 0: Impossible 1: Possible	This setting is effective only when Automatic Journal printout is enabled but the machine cannot print the report (e.g., no paper). 0: If the buffer memory of the communication records for the Journal has become full, fax communications will become impossible, to prevent overwriting the communication records before the machine prints them out. 1: If the buffer memory of the communication records for the Journal is full, fax communications are still possible. But the machine will overwrite the oldest communication records. Cross Reference <input type="checkbox"/> Automatic Journal output - User switch 03 bit 7 <input type="checkbox"/> Number of communication records for the Journal: 200 records (standard) 1000 records (with the Function Upgrade unit installed)
1	Action when the SAF memory has become full during scanning 0: The current page is erased. 1: The entire file is erased.	0: If the SAF memory becomes full during scanning, the successfully scanned pages are transmitted. 1: If the SAF memory becomes full during scanning, the file is erased and no pages are transmitted. This bit switch is ignored for parallel memory transmission.
2	RTI/CSI display priority 0: RTI 1: CSI	This bit determines which identifier, RTI or CSI, is displayed on the LCD while the machine is communicating in G3 non-standard mode.
3	File No. printing 0: Enabled 1: Disabled	1: File numbers are not printed on any reports.
4	Action when authorized reception is enabled but authorized RTIs/CSIs are not yet programmed 0: All fax reception is disabled 1: Faxes can be received if the sender has an RTI or CSI	If authorized reception is enabled but the user has stored no acceptable sender RTIs or CSIs, the machine will not be able to receive any fax messages. If the customer wishes to receive messages from any sender that includes an RTI or CSI, and to block messages from senders that do not include an RTI or CSI, change this bit to "1", then enable Authorized Reception. Otherwise, keep this bit at "0 (default setting)".

System Switch 1E		SP No. 1-101-031
No	FUNCTION	COMMENTS
5	Address display priority in the AI redial mode 0: RTI/CSI 1: Telephone number	0: When the machine has both RTI/CSI and the telephone number information, the machine displays RTI/CSI. 1: The machine always displays the telephone number.
6	Not used	Do not change the settings
7	RAM initialization after the optional Function Upgrade unit is installed or removed 0: Enabled 1: Disabled	<p>When the machine detects that a Function Upgrade unit has been installed or removed, the machine shows the following message on the display for the customer.</p> <p><i>“Adding/Removing FAX Feature Expander causes data loss. Turn Main Power Switch off and remove/replace it to avoid loss. To continue, press Yes.”</i></p> <p>If Yes is pressed, the machine initializes the RAM to the “with” or “without card” configuration. However, changing this bit to “1” disables this initialization, even if Yes is pressed.</p> <p>Change this bit to 1 after installing the Function Upgrade unit.</p> <p>0: When the above message is displayed, the machine initializes the RAM if Yes is pressed. The amount of data lost depends on whether the board is in or out. To avoid losing data, the user must switch off immediately and put the Function Upgrade unit back in.</p> <p>1: When the above message is displayed, the machine does not initialize the RAM even if Yes is pressed. However, the fax unit cannot be used until the user switches off, puts the Function Upgrade unit back in, then switches back on. No data is lost.</p>

System Switch 1F		SP No. 1-101-032
No	FUNCTION	COMMENTS
0	Not used	Do not change the settings.
1	Report printout after an original jam during SAF storage or if the SAF memory fills up 0: Enabled 1: Disabled	0: When an original jams, or the SAF memory overflows during scanning, a report will be printed. Change this bit to "1" if the customer does not want to have a report in these cases. Memory tx – Memory storage report Parallel memory tx – Transmission result report
2	Not used	Do not change the settings.
3	Received fax print start timing (G3 reception) 0: After receiving each page 1: After receiving all pages	0: The machine prints each page immediately after the machine receives it. 1: The machine prints the complete message after the machine receives all the pages in the memory.
4	Received fax print start timing (G4 reception) 0: After receiving each page 1: After receiving all pages	
5-6	Not used	Do not change the factory settings.
7	Action when a fax SC has occurred 0: Automatic reset 1: Fax unit stops	0: When the fax unit detects a fax SC code other than SC1201 and SC1207, the fax unit automatically resets itself. 1: When the fax unit detects any fax SC code, the fax unit stops. Cross Reference Fax SC codes - See "Troubleshooting"

4.2.2 SCANNER SWITCHES

Scanner Switch 00 - Not used (do not change the settings)

Scanner Switch 01		SP No. 1-102-002
No	FUNCTION	COMMENTS
0-7	Scan density step value (Text mode)	<p>When scan density is adjusted manually away from the Normal setting, the threshold value for binary picture processing changes for each step from the value specified by Scanner Switch 02, by the amount programmed here.</p> <p>For example, with the default setting (14), the threshold value changes as follows.</p> <p>+3 (Darkest) : 71 (= 85 – 14) +2 : 85 (= 99 – 14) +1 : 99 (= 113 – 14) 0 (Normal) : 113 (Scanner Switch 02 setting) -1 : 127 (= 113 + 14) -2 : 141 (= 127 + 14) -3 (Lightest) : 155 (= 141 + 14)</p> <p>For smaller steps, input a lower value.</p>

Scanner Switch 02		SP No. 1-102-003
No	FUNCTION	COMMENTS
0-7	Binary picture processing: Threshold for Text mode - Normal setting (center position)	<p>This setting determines the threshold value for binary picture processing in Text mode (when the scan density setting is at the center).</p> <p>The value can be between 01 and FF. For a darker threshold, input a lower value.</p> <p>Default setting: 71(H) = 113(D)</p>

Scanner Switch 03 - Not used (do not change the settings)

Scanner Switch 04		SP No. 1-102-005
No	FUNCTION	COMMENTS
0-7	Binary picture processing: Threshold for monotone background special original 1 mode - Normal setting (center position)	<p>This setting determines the threshold value for binary picture processing in monotone background special original 1 mode (when the scan density setting is at the center).</p> <p>The value can be between 01 and FF. For a darker threshold, input a lower value.</p> <p>Default setting: A4(H) = 164(D)</p>

Scanner Switch 05		SP No. 1-102-006
No	FUNCTION	COMMENTS
0-7	Binary picture processing: Threshold for colored background special original 2 mode - Normal setting (center position)	This setting determines the threshold value for binary picture processing in colored background special original 2 mode (when the scan density setting is at the center). The value can be between 01 and FF. For a darker threshold, input a lower value. Default setting: 28(H) = 40(D)

Scanner Switch 06		SP No. 1-102-007
No	FUNCTION	COMMENTS
0 to 3	MTF filter level (Text mode) The value can be between 0(Off) and F. For a weaker threshold, input a lower value. Default setting: 7 This setting is independent from the threshold specified by the copier SP modes.	
4 to 7	MTF filter level (Text/Photo mode) The value can be between 0(Off) and F. For a weaker threshold, input a lower value. Default setting: 7 This setting is independent from the threshold specified by the copier SP modes.	

Scanner Switch 07		SP No. 1-102-008
No	FUNCTION	COMMENTS
0 to 2	Smoothing filter level (Photo mode)	The value can be between 0(Off) and 7. For a weaker threshold, input a lower value. Default setting: 2 This setting is independent from the threshold setting specified by the copier SP modes.
3-7	Not used	Do not change the settings.

Scanner Switch 08 - Not used (do not change the settings)
Scanner Switch 09 - Not used (do not change the settings)

Scanner Switch 0A		SP No. 1-102-011
No	FUNCTION	COMMENTS
0-3	Not used	Do not change the settings
4-7	MTF filter level (Color mode) The value can be between 0(Off) and F. For a weaker threshold, input a lower value. Default setting: 7 This setting is independent from the threshold specified by the copier SP modes.	

Scanner Switch 0B		SP No. 1-102-012
No	FUNCTION	COMMENTS
0-3	Scan margin setting (right and left margin in book scan ADF mode) The setting can be between 0 and F (H) (unit 0.5 mm). Default setting: 2 mm	
4-7	Scan margin setting (top and bottom margin in book scan and ADF mode) The setting can be between 0 and 7 (H) (unit 0.5 mm). Default setting: 3 mm	

Scanner Switch 0C		SP No. 1-102-013
No	FUNCTION	COMMENTS
0	Action when an original jam has occurred while scanning the original into memory for memory tx 0: Continues scanning after recovery 1: Stops scanning and erases all scanned pages for that job	This bit is only effective when parallel memory tx is disabled (user parameter 07 - bit 2). If parallel memory tx is enabled, the machine always erases the scanned pages when an original jam occurs. The machine then asks the user to retry from the first page, even if the parallel memory tx is not actually used. 0: The machine displays a message asking the user to put the jammed page back into the original stack, and continues scanning. The message is displayed for the time period specified by scanner switch 0E, bit 2. 1: The machine erases all the scanned pages and asks the user to retry from the first page.
1 to 2	Setting when an original size cannot be recognized Bit 2 1 Setting 0 0 No original 0 1 A5 □ 1 0 A5 □ 1 1 No original	
3-5	Not used	Do not change the settings.
6	Scan width used for a document set in the ADF when the width is less than 230 mm. 0: A4 (210 mm) 1: LT (216 mm)	This bit is set at "1" when the country code is set to the US.
7	Not used	Do not change the settings.

Service Tables

Scanner Switch 0D		SP No. 1-102-014
No	FUNCTION	COMMENTS
0-6	Not used	Do not change the settings.
7	Scan width for A5 lengthwise or B5 lengthwise originals 0: 210 mm (8.5") 1: Original width	0: The machine scans the original as 210 mm (8.5") width. The transmitted image has a blank area on the right. 1: The machine scans 148 mm (A5) or 182 mm (B5) and centers the scanned data on a 216 mm width transmitted image.

Scanner Switch 0E		SP No. 1-102-015
No	FUNCTION	COMMENTS
0	Wait time for the next page when scanning a book original into memory 0: 60 s 1: 30 s	This bit determines how long the machine waits for the next page when scanning a book original for memory transmission. If this timer expires, the machine transmits all the pages scanned so far as one document. Note: In immediate tx or parallel memory tx, the wait time for the next page is 10 s.
1	Scan resolution unit 0: mm 1: inches	This bit determines which resolution unit will be used for scanning a fax message. Default setting: mm
2	ADF jam alarm display time 0: 60 s 1: 30 s	The bit is only effective when bit 0 of scanner bit switch 0C is "0". This bit determines how long the machine displays the ADF jam alarm after a jam occurred.
3-7	Not used	Do not change the settings.

Scanner Switch 0F		SP No. 1-102-016
No	FUNCTION	COMMENTS
0	Image rotation before transmission (A4/LT sideways) 0: Disabled 1: Enabled	This bit determines whether the machine rotates the scanned image by 90 degrees before transmission. If this bit is set at 1, A4 (LT) sideways images (297 mm width in the protocol) will be transmitted as A4 (LT) lengthwise images (216 mm width in the protocol).
1	Not used	Do not change the settings
2	Image rotation before transmission (A5/HLT lengthwise) 0: Disabled 1: Enabled	This bit determines whether the machine rotates the scanned image by 90 degrees before transmission. If this bit is set at "1", A5 (HLT) lengthwise images will be transmitted as A4 (LT) width images (216 mm width in the protocol).
3-7	Not used	Do not change the settings.

4.2.3 PRINTER SWITCHES

Printer Switch 00		SP No. 1-103-001
No	FUNCTION	COMMENTS
0	Page separation mark 0: Disabled 1: Enabled	0: No marks are printed. 1: If a received page has to be printed out on two sheets, an asterisk inside square brackets is printed at the bottom right hand corner of the first sheet, and a "2" inside a small box is printed at the top right hand corner of the second sheet. This helps the user to identify pages that have been split.
1	Repetition of data when the received page is longer than the printer paper 0: Disabled 1: Enabled	0: The next page continues from where the previous page left off. 1: The final few mm of the previous page are repeated at the top of the next page. The amount of repeated data depends on printer switch 04, bits 5 and 6.
2	Prints the date and time on received fax messages 0: Disabled 1: Enabled	This switch is only effective when user parameter 02 - bit 2 (printing the received date and time on received fax messages) is enabled. 1: The machine prints the received and printed date and time at the bottom of each received page.
3-7	Not used	Do not change the settings.

Service Tables

Printer Switch 01		SP No. 1-103-002
No	FUNCTION	COMMENTS
0-2	Not used	Do not change the settings.
3-4	Maximum print width used in the setup protocol Bit 4 3 Setting 0 0 Not used 0 1 A3 1 0 B4 1 1 A4	These bits are only effective when bit 7 of printer switch 01 is "1".
5-6	Not used	Do not change the settings.
7	Received message width restriction in the protocol signal to the sender 0: Disabled 1: Enabled	0: The machine informs the transmitting machine of the print width depending on the paper size available from the paper feed stations. Refer to the table on the next page for how the machine chooses the paper width used in the setup protocol (NSF/DIS). 1: The machine informs the transmitting machine of the fixed paper width which is specified by bits 3 and 4 above.

Relationship between available paper sizes and printer width used in the setup protocol

Available Paper Size	Printer width used in the Protocol (NSF/DIS)
A4 or 8.5" x 11"	297 mm width
B5	256 mm width
A5 or 8.5" x 5.5"	216 mm width
No paper available (Paper end)	216 mm width

Printer Switch 02		SP No. 1-103-003
No	FUNCTION	COMMENTS
0	1st paper feed station usage for fax printing 0: Enabled 1: Disabled	<p>0: The paper feed station can be used to print fax messages and reports.</p> <p>1: The specified paper feed station will not be used for printing fax messages and reports.</p> <p>Note: Do not disable usage for a paper feed station which has been specified by User Parameter Switch 0F (15), or which is used for the Specified Cassette Selection feature.</p>
1	2nd paper feed station usage for fax printing 0: Enabled 1: Disabled	
2	3rd paper feed station usage for fax printing 0: Enabled 1: Disabled	
3	4th paper feed station usage for fax printing 0: Enabled 1: Disabled	
4	LCT usage for fax printing 0: Enabled 1: Disabled	
5-7	Not used	Do not change the settings.

Printer Switch 03		SP No. 1-103-004						
No	FUNCTION	COMMENTS						
0	Length reduction of received data 0: Disabled 1: Enabled	0: Incoming pages are printed without length reduction. (Page separation threshold: Printer Switch 03, bits 4 to 7) 1: Incoming page length is reduced when printing. (Maximum reducible length: Printer Switches 04, bits 0 to 4)						
1-3	Not used	Do not change the settings						
4 to 7	Page separation threshold (with reduction disabled with switch 03-0 above) If the incoming page is up to x mm longer than the length of copy paper, the excess portion will not be printed. If the incoming page is more than x mm longer than the length of copy paper, the excess portion will be printed on the next page. The value of x is determined by these four bits. Hex value of bits 4 to 7 x (mm) <table style="margin-left: 40px;"> <tr><td>0</td><td>0</td></tr> <tr><td>1</td><td>1</td></tr> </table> and so on until <table style="margin-left: 40px;"> <tr><td>F</td><td>15</td></tr> </table> Default setting: 6 mm Cross reference Length reduction On/Off: Printer Switch 03, Bit 0	0	0	1	1	F	15	
0	0							
1	1							
F	15							

Service Tables

Printer Switch 04		SP No. 1-103-005																																										
No	FUNCTION	COMMENTS																																										
0 to 4	Maximum reducible length when length reduction is enabled with switch 03-0 above. <Maximum reducible length> = <Paper length> + (N x 5mm) "N" is the decimal value of the binary setting of bits 0 to 4. <table style="margin-left: 20px;"> <tr><td>Bit 4</td><td>3</td><td>2</td><td>1</td><td>0</td><td>Setting</td></tr> <tr><td>0</td><td>0</td><td>0</td><td>0</td><td>0</td><td>0 mm</td></tr> <tr><td>0</td><td>0</td><td>0</td><td>0</td><td>1</td><td>5 mm</td></tr> <tr><td colspan="6"> </td></tr> <tr><td>0</td><td>0</td><td>1</td><td>0</td><td>0</td><td>20 mm (default setting)</td></tr> <tr><td colspan="6"> </td></tr> <tr><td>1</td><td>1</td><td>1</td><td>1</td><td>1</td><td>155 mm</td></tr> </table> For A5 sideways and B5 sideways paper <Maximum reducible length> = <Paper length> + 0.75 x (N x 5mm)	Bit 4	3	2	1	0	Setting	0	0	0	0	0	0 mm	0	0	0	0	1	5 mm							0	0	1	0	0	20 mm (default setting)							1	1	1	1	1	155 mm	
Bit 4	3	2	1	0	Setting																																							
0	0	0	0	0	0 mm																																							
0	0	0	0	1	5 mm																																							
0	0	1	0	0	20 mm (default setting)																																							
1	1	1	1	1	155 mm																																							
5 to 6	Length of the duplicated image on the next page, when page separation has taken place. $\begin{pmatrix} 0 \\ 0 \end{pmatrix} = 4\text{ mm}$ $\begin{pmatrix} 1 \\ 0 \end{pmatrix} = 10\text{ mm}$ $\begin{pmatrix} 0 \\ 1 \end{pmatrix} = 15\text{ mm}$ $\begin{pmatrix} 1 \\ 1 \end{pmatrix} = \text{Not used}$																																											
7	Not used.	Do not change the setting.																																										

Printer Switch 05 - Not used (do not change the settings)

Printer Switch 06		SP No. 1-103-007
No	FUNCTION	COMMENTS
0	Printing while a paper cassette is pulled out, when the Just Size Printing feature is enabled. 0: Printing will not start 1: Printing will start if another cassette has a suitable size of paper, based on the paper size selection priority tables.	Cross reference Just size printing on/off – User switch 05, bit 5
1-7	Not used.	Do not change the settings.

Printer Switch 07		SP No. 1-103-008
No	FUNCTION	COMMENTS
0	Reduction for Journal printing 0: Off 1: On	1: The Journal is reduced to 91% to ensure that there is enough space in the left margin for punch holes or staples.
2-3	Not used.	Do not change the settings.
4	List of destinations in the Communication Failure Report for broadcasting 0: All destinations 1: Only destinations where communication failure occurred	1: Only destinations where communication failure occurred are printed on the Communication Failure Report.
5-7	Not used.	Do not change the settings.

Printer Switch 08 - Not used (do not change the settings)
Printer Switch 09 - Not used (do not change the settings)
Printer Switch 0A - Not used (do not change the settings)
Printer Switch 0B - Not used (do not change the settings)
Printer Switch 0C - Not used (do not change the settings)
Printer Switch 0D - Not used (do not change the settings)

Printer Switch 0E		SP No. 1-103-015
No	FUNCTION	COMMENTS
0	Paper size selection priority 0: Width 1: Length	0: A paper size that has the same width as the received data is selected first. 1: A paper size which has enough length to print all the received lines without reduction is selected first.
1	Paper size selected for printing A4 width fax data 0: 8.5" x 11" size 1: A4 size	This switch determines which paper size is selected for printing A4 width fax data, when the machine has both A4 and 8.5" x 11" size paper.
2	Page separation 0: Enabled 1: Disabled	1: If all paper sizes in the machine require page separation to print a received fax message, the machine does not print the message (Substitute Reception is used). After a larger size of paper is set in a cassette, the machine automatically prints the fax message.
3 to 4	Printing the sample image on reports Bit 4 Bit 3 Setting 0 0 The upper half only 0 1 50% reduction in sub-scan only 1 0 Same size 1 1 Not used	"Same size" means the sample image is printed at 100%, even if page separation occurs. User Parameter Switch 19 (13H) bit 4 must be set to "0" to enable this switch. Refer to Detailed Section Descriptions for more on this feature.
5-6	Not used	Do not change the settings.
7	Equalizing the reduction ratio among separated pages (Page Separation) 0: Enabled 1: Disabled	0: When page separation has taken place, all the pages are reduced with the same reduction ratio. 1: Only the last page is reduced to fit the selected paper size when page separation has taken place. Other pages are printed without reduction.

Service Tables

Printer Switch 0F		SP No. 1-103-016
No	FUNCTION	COMMENTS
0 to 1	Smoothing feature Bit 1 Bit 0 Setting 0 0 Disabled 0 1 Disabled 1 0 Enabled 1 1 Not used	(0, 0) (0, 1): Disable smoothing if the machine receives halftone images from other manufacturers fax machines frequently.
2	Duplex printing 0: Disabled 1: Enabled	1: The machine always prints received fax messages in duplex printing mode:
3	Binding direction for Duplex printing 0: Left binding 1: Top binding	
4	Printing fax messages in user code mode 0: Enabled 1: Disabled	1: The machine holds the received fax messages until the machine exits the restricted access mode (user code or key counter). If the machine enters the restricted access mode again while printing fax messages, the machine stops printing the machine exits the mode again.
5-7	Not used	Do not change the settings.

4.2.4 COMMUNICATION SWITCHES

Communication Switch 00		SP No. 1-104-001
No	FUNCTION	COMMENTS
0 to 1	Compression modes available in receive mode Bit 1 0 Modes 0 0 MH only 0 1 MH/MR 1 0 MH/MR/MMR 1 1 MH/MR/MMR/ JBIG	These bits determine the compression capabilities to be declared in phase B (handshaking) of the T.30 protocol.
2 to 3	Compression modes available in transmit mode Bit 3 2 Modes 0 0 MH only 0 1 MH/MR 1 0 MH/MR/MMR 1 1 MH/MR/MMR/ JBIG	These bits determine the compression capabilities to be used in the transmission and to be declared in phase B (handshaking) of the T.30 protocol.
4	Not used	Do not change the settings.
5	JBIG compression method: Reception 0 : Only basic supported 1 : Basic and optional both supported	Change the setting when communication problems occur using JBIG compression.
6	JBIG compression method: Transmission 0 : Basic mode priority 1 : Optional mode priority	Change the setting when communication problems occur using JBIG compression.
7	Closed network (reception) 0 : Disabled 1 : Enabled	1 : Reception will not go ahead if the ID code of the other terminal does not match the ID code of this terminal. This function is only available in NSF/NSS mode.

Service
Tables

Communication Switch 01			SP No. 1-104-002															
No	FUNCTION		COMMENTS															
0	ECM 0: Off 1: On		If this bit is set to 0, ECM is switched off for all communications. In addition, V.8 protocol and JBIG compression are switched off automatically.															
1	Not used		Do not change the setting.															
2 to 3	Wrong connection prevention method	<table border="1"> <thead> <tr> <th>Bit 3</th> <th>Bit 2</th> <th>Setting</th> </tr> </thead> <tbody> <tr> <td>0</td> <td>0</td> <td>None</td> </tr> <tr> <td>0</td> <td>1</td> <td>8 digit CSI</td> </tr> <tr> <td>1</td> <td>0</td> <td>4 digit CSI</td> </tr> <tr> <td>1</td> <td>1</td> <td>CSI/RTI</td> </tr> </tbody> </table>	Bit 3	Bit 2	Setting	0	0	None	0	1	8 digit CSI	1	0	4 digit CSI	1	1	CSI/RTI	<p>(0,1) - The machine will disconnect the line without sending a fax message, if the last 8 digits of the received CSI do not match the last 8 digits of the dialed telephone number. This does not work when manually dialed.</p> <p>(1,0) - The same as above, except that only the last 4 digits are compared.</p> <p>(1,1) - The machine will disconnect the line without sending a fax message, if the other end does not identify itself with an RTI or CSI.</p> <p>(0,0) - Nothing is checked; transmission will always go ahead.</p> <p>Note: This function does not work when dialing is done from the external telephone.</p>
Bit 3	Bit 2	Setting																
0	0	None																
0	1	8 digit CSI																
1	0	4 digit CSI																
1	1	CSI/RTI																
4-5	Not used		Do not change the setting.															
6 to 7	Maximum printable page length available	<table border="1"> <thead> <tr> <th>Bit 7</th> <th>6</th> <th>Setting</th> </tr> </thead> <tbody> <tr> <td>0</td> <td>0</td> <td>No limit</td> </tr> <tr> <td>0</td> <td>1</td> <td>B4 (364 mm)</td> </tr> <tr> <td>1</td> <td>0</td> <td>A4 (297 mm)</td> </tr> <tr> <td>1</td> <td>1</td> <td>Not used</td> </tr> </tbody> </table>	Bit 7	6	Setting	0	0	No limit	0	1	B4 (364 mm)	1	0	A4 (297 mm)	1	1	Not used	The setting determined by these bits is informed to the transmitting terminal in the pre-message protocol exchange (in the DIS/NSF frames).
Bit 7	6	Setting																
0	0	No limit																
0	1	B4 (364 mm)																
1	0	A4 (297 mm)																
1	1	Not used																

Communication Switch 02			SP No. 1-104-003																
No	FUNCTION		COMMENTS																
0	Burst error threshold 0: Low 1: High		<p>If there are more consecutive error lines in the received page than the threshold, the machine will send a negative response.</p> <p>The Low and High threshold values depend on the sub-scan resolution, and are as follows.</p> <table border="1"> <thead> <tr> <th>Resolution</th> <th>100 dpi</th> <th>200 dpi</th> <th>400 dpi</th> </tr> </thead> <tbody> <tr> <td></td> <td>3.85 l/mm</td> <td>7.7 l/mm</td> <td>15.4 l/mm</td> </tr> <tr> <td>Low settings</td> <td>6</td> <td>12</td> <td>24</td> </tr> <tr> <td>High settings</td> <td>12</td> <td>24</td> <td>48</td> </tr> </tbody> </table>	Resolution	100 dpi	200 dpi	400 dpi		3.85 l/mm	7.7 l/mm	15.4 l/mm	Low settings	6	12	24	High settings	12	24	48
Resolution	100 dpi	200 dpi	400 dpi																
	3.85 l/mm	7.7 l/mm	15.4 l/mm																
Low settings	6	12	24																
High settings	12	24	48																
1	Acceptable total error line ratio 0: 5% 1: 10%		If the error line ratio for a page exceeds the acceptable ratio, RTN will be sent to the other end.																
2	Treatment of pages received with errors during G3 reception 0: Deleted from memory without printing 1: Printed		0: Pages received with errors are not printed.																

Communication Switch 02		SP No. 1-104-003
No	FUNCTION	COMMENTS
3	Hang-up decision when a negative code (RTN or PIN) is received during G3 immediate transmission 0: No hang-up, 1: Hang-up	0: The next page will be sent even if RTN or PIN is received. 1: The machine will send DCN and hang up if it receives RTN or PIN. This bit is ignored for memory transmissions or if ECM is being used.
4-7	Not used	Do not change the settings.

Communication Switch 03		SP No. 1-104-004
No	FUNCTION	COMMENTS
0 to 7	Maximum number of page retransmissions in a G3 memory transmission	00 - FF (Hex) times. This setting is not used if ECM is switched on. Default setting - 03(H)

Communication Switch 04 - Not used (do not change the settings)
Communication Switch 05 - Not used (do not change the settings)
Communication Switch 06 - Not used (do not change the settings)

Communication Switch 07		SP No. 1-104-008
No	FUNCTION	COMMENTS
0	Fallback from G4 to G3 if the other terminal is not a G4 terminal 0: Disabled 1: Enabled	Also see system switch 0A bit 7. Refer to G4 Internal Switches 17, 18, 1A, 1B, and 1C for the CPS code set (Cause Value set) that determines G4 to G3 fallback.
1	Not used	Do not change the setting.
2	Not used	Do not change the setting.
3	Fallback from G4 to G3 reflected in programmed Quick/Speed dials 0: Fallback enabled 1: Always start with G4	0: If a communication falls back from G4 to G3, the machine will always start transmission with G3 from the next communication. 1: The machine will always start to transmit with G4.
4	Fallback from G4 to G3 when G4 communication fails on the ISDN B-channel 0: Fallback disabled 1: Fallback enabled	1: Enable this switch only when G4 communication errors occur because the exchanger connects G4 calls to the PSTN. This problem occurs with some types of exchanger.
5	Not used	Do not change the setting.
6	Not used	Do not change the setting.
7	Not used	Do not change the setting.

Communication Switch 08 - Not used (do not change the settings)
Communication Switch 09 - Not used (do not change the settings)

Communication Switch 0A		SP No. 1-104-011
No	FUNCTION	COMMENTS
0	Point of resumption of memory transmission upon redialing 0: From the error page 1: From page 1	0: The transmission begins from the page where transmission failed the previous time. 1: Transmission begins from the first page, using normal memory transmission.
1-6	Not used	Do not change the settings.
7	Emergency calls using 999 0: Enabled 1: Disabled	If this bit is at 1, the machine will not allow you to dial 999 at the auto-dialer. This is a PTT requirement in the Hong Kong.

Communication Switch 0B		SP No. 1-104-012
No	FUNCTION	COMMENTS
0	Use of Economy Transmission during a Transfer operation to end receivers 0: Disabled 1: Enabled	These bits determine whether the machine uses the Economy Transmission feature when it is carrying out a Transfer operation as a Transfer Station.
1	Use of Economy Transmission during a Transfer operation to the Next Transfer Stations 0: Disabled 1: Enabled	
2	Use of Label Insertion for the End Receivers in a Transfer operation 0: Disabled 1: Enabled	This bit determines whether the machine uses the Label Insertion feature when it is carrying out a Transfer operation as a Transfer Station.
3	Conditions required for Transfer Result Report transmission 0: Always transmitted 1: Only transmitted if there was an error	0: When acting as a Transfer Station, the machine will always send a Transfer Result Report back to the Requesting Station after completing the Transfer Request, even if there were no problems. 1: The machine will only send back a Transfer Result Report if there were errors during communication, meaning one or more of the End Receivers could not be contacted.
4	Printout of the message when acting as a Transfer Station 0: Disabled 1: Enabled	When the machine is acting as a Transfer Station, this bit determines whether the machine prints the fax message coming in from the Requesting Terminal.

Communication Switch 0B		SP No. 1-104-012
No	FUNCTION	COMMENTS
5	Action when there is no fax number in the programmed Quick/Speed dials which meets the requesting terminal's own fax number 0: Transfer is disabled 1: Transfer is enabled	After the machine receives a transfer request, the machine compares the last N digits of the requesting terminal's own fax number with all the Quick/Speed dials programmed in the machine. (N is the number programmed in communication switch 0C.) 0: If there is no matching number programmed in the machine, the machine rejects the transfer request. 1: Even if there is no matching number programmed in the machine, the machine accepts the transfer request. The result report will be printed at the transfer terminal, but will not be sent back to the requesting terminal.
6-7	Not used	Do not change the settings.

Communication Switch 0C		SP No. 1-104-013
No	FUNCTION	COMMENTS
0 to 4	Number of digits compared to find the requester's fax number from the programmed Quick/Speed Dials when acting as a Transfer Station	00 - 1F (0 to 31 digits) After the machine receives a transfer request, the machine compares the own telephone number sent from the Requesting Terminal with all Quick/Speed Dials programmed in the machine, starting from Quick Dial 01 to the end of the Speed Dials. This number determines how many digits from the end of the telephone numbers the machine compares. If it is set to 00, the machine will send the report to the first Quick/Speed Dial that the machine compared. If Quick Dial 01 is programmed, the machine will send the report to Quick 01. If Quick Dial 01 through 04 are not programmed and Quick Dial 05 is programmed, the machine will send the report to Quick 05. Default setting - 05(H) = 5 digits
5-7	Not used	Do not change the settings.

Service Tables

Communication Switch 0D		SP No. 1-104-014
No	FUNCTION	COMMENTS
0 to 7	The available memory threshold, below which ringing detection (and therefore reception into memory) is disabled	00 to FF (Hex), unit = 4 kbytes (e.g., 06(H) = 24 kbytes) One page is about 24 kbytes. The machine refers to this setting before each fax reception. If the amount of remaining memory is below this threshold, the machine cannot receive any fax messages. If this setting is kept at 0, the machine will detect ringing signals and go into receive mode even if there is no memory available. This will result in communication failure.

Communication Switch 0E		SP No. 1-104-015
No	FUNCTION	COMMENTS
0 to 7	Minimum interval between automatic dialing attempts	06 to FF (Hex), unit = 2 s (e.g., 06(H) = 12 s) This value is the minimum time that the machine waits before it dials the next destination.

Communication Switch 0F - Not used (do not change the settings.)

Communication Switch 10		SP No. 1-104-017
No	FUNCTION	COMMENTS
0 to 7	Memory transmission: Maximum number of dialing attempts to the same destination	01 - FE (Hex) times

Communication Switch 11 - Not used (do not change the settings.)

Communication Switch 12		SP No. 1-104-019
No	FUNCTION	COMMENTS
0 to 7	Memory transmission: Interval between dialing attempts to the same destination	01 - FF (Hex) minutes

Communication Switch 13 - Not used (do not change the settings.)

Communication Switch 14			SP No. 1-104-021
No	FUNCTION	COMMENTS	
0	Inch-to-mm conversion during transmission 0: Disabled 1: Enabled	<p>0: In immediate transmission, data scanned in inch format are transmitted without conversion. In memory transmission, data stored in the SAF memory in mm format are transmitted without conversion.</p> <p>Note: When storing the scanned data into SAF memory, the fax unit always converts the data into mm format.</p> <p>1: The machine converts the scanned data or stored data in the SAF memory to the format which was specified in the set-up protocol (DIS/NSF) before transmission.</p>	
1-5	Not used	Do not change the factory settings.	
6 to 7	Available unit of resolution in which fax messages are received Bit 7 Bit 6 Unit 0 0 mm 0 1 inch 1 0 mm and inch (default) 1 1 Not used	<p>For the best performance, do not change the factory settings.</p> <p>The setting determined by these bits is informed to the transmitting terminal in the pre-message protocol exchange (in the DIS/NSF frames).</p>	

Service Tables

Communication Switch 15 - Not used (do not change the settings)

Communication Switch 16			SP No. 1-104-023
No	FUNCTION	COMMENTS	
0	Standard G3 unit 0: Disabled 1: Enabled	<p>Set this bit to 0 if the user wants to use only the ISDN line (option G4 unit), even for G3 communications. However, for ISDN on hook dialing, bit 7 of user parameter 30 must be set to 1.</p> <p>Note: If the optional G4 unit is not installed, but this bit is changed to 'disabled', no document can be transmitted.</p>	
1	Optional G3 unit (G3-2) 0: Not installed 1: Installed	Change this bit to 1 when installing the first optional G3 unit.	
2	Optional ISDN unit 0: Not installed 1: Installed	Change this bit to 1 when installing the optional ISDN unit.	
3-5	Not used	Do not change the settings.	
6	Use of the I-G3 line 0: Tx or rx 1: Tx only	Change this bit to 1 when the customer requires.	

Communication Switch 16		SP No. 1-104-023
No	FUNCTION	COMMENTS
7	G4 Dual communication 0: Enabled 1: Disabled	1: The machine uses only one B channel for communication. This enables a customer to occupy another B channel for other purposes such as internet communication.

Communication Switch 17		SP No. 1-104-024
No	FUNCTION	COMMENTS
0	SEP reception 0: Disabled 1: Enabled	0: Polling transmission to another maker's machine using the SEP (Selective Polling) signal is disabled.
1	SUB reception 0: Disabled 1: Enabled	0: Confidential reception to another maker's machine using the SUB (Sub-address) signal is disabled.
2	PWD reception 0: Disabled 1: Enabled	0: Disables features that require PWD (Password) signal reception.
3-6	Not used	Do not change the settings.
7	Action when there is no box with an F-code that matches the received SUB code 0: Disconnect the line 1: Receive the message (using normal reception mode)	Change this setting when the customer requires.

Communication Switch 18 - Not used (do not change the settings)
Communication Switch 19 - Not used (do not change the settings)
Communication Switch 1A - Not used (do not change the settings)

Communication Switch 1B		SP No. 1-104-028
No	FUNCTION	COMMENTS
0 to 7	Extension access code (0 to 7) to turn V.8 protocol On/Off 0: On 1: Off	If the PABX does not support V.8/V.34 protocol procedure, set this bit to "1" to disable V.8. Example: If "0" is the PSTN access code, set bit 0 to 1. When the machine detects "0" as the first dialed number, it automatically disables V.8 protocol. (Alternatively, if "3" is the PSTN access code, set bit 3 to 1.)

Communication Switch 1C		SP No. 1-104-029
No	FUNCTION	COMMENTS
0 to 1	Extension access code (8 and 9) to turn V.8 protocol On/Off 0: On 1: Off	Refer to communication switch 1B. Example: If "8" is the PSTN access code, set bit 0 to 1. When the machine detects "8" as the first dialed number, it automatically disables V.8 protocol. (If "9" is the PSTN access code, use bit 1.)
2-7	Not used	Do not change the settings.

Communication Switch 1D - Not used (do not change the settings)
Communication Switch 1E - Not used (do not change the settings)
Communication Switch 1F - Not used (do not change the settings)

4.2.5 G3 SWITCHES

G3 Switch 00		SP No. 1-105-001
No	FUNCTION	COMMENTS
0 1	Monitor speaker during communication (tx and rx) Bit 1 Bit 0 Setting 0 0 Disabled 0 1 Up to Phase B 1 0 All the time 1 1 Not used	(0, 0): The monitor speaker is disabled all through the communication. (0, 1): The monitor speaker is on up to phase B in the T.30 protocol. (1, 0): Used for testing. The monitor speaker is on all through the communication. Make sure that you reset these bits after testing.
2	Monitor speaker during memory transmission 0: Disabled 1: Enabled	1: The monitor speaker is enabled during memory transmission.
3-7	Not used	Do not change the settings.

G3 Switch 01		SP No. 1-105-002
No	FUNCTION	COMMENTS
0-3	Not used	Do not change the settings.
4	DIS frame length 0: 10 bytes 1: 4 bytes	1: The bytes in the DIS frame after the 4th byte will not be transmitted (set to 1 if there are communication problems with PC-based faxes which cannot receive the extended DIS frames).
5	Not used	Do not change the setting.
6	CED/ANSam transmission 0: Disabled 1: Enabled	Do not change this setting, unless the communication problem is caused by the CED/ANSam transmission.
7	Not used	Do not change the setting.

G3 Switch 02		SP No. 1-105-003
No	FUNCTION	COMMENTS
0	G3 protocol mode used 0: Standard and non-standard 1: Standard only	Change this bit to 1 only when the other end can only communicate with machines that send T.30-standard frames only. 1: Disables NSF/NSS signals (these are used in non-standard mode communication)
1-4	Not used	Do not change the settings.
5	Use of modem rate history for transmission using Quick/Speed Dials 0: Disabled 1: Enabled	0: Communications using Quick/Speed Dials always start from the highest modem rate. 1: The machine refers to the modem rate history for communications with the same machine when determining the most suitable rate for the current communication.
6	AI short protocol (transmission and reception) 0: Disabled 1: Enabled	Refer to Appendix B in the Group 3 Facsimile Manual for details about AI Short Protocol.
7	Short preamble 0: Disabled 1: Enabled	Refer to Appendix B in the Group 3 Facsimile Manual for details about Short Preamble.

G3 Switch 03		SP No. 1-105-004
No	FUNCTION	COMMENTS
0	DIS detection number (Echo countermeasure) 0: 1 1: 2	0: The machine will hang up if it receives the same DIS frame twice. 1: Before sending DCS, the machine will wait for the second DIS which is caused by echo on the line.
1	V.8 protocol in manual reception 0: Disabled 1: Enabled	0: The machine sends CED instead of ANSam when starting a manual reception. 1: The machine sends ANSam during manual reception.
2	V.8 protocol 0: Disabled 1: Enabled	0: V.8/V.34 communications will not be possible. Note: Do not set to 0 unless the line condition is always bad enough to slow down the data rate to 14.4 kbps or lower.
3	ECM frame size 0: 256 bytes 1: 64 bytes	Keep this bit at "0" in most cases.
4	CTC transmission conditions 0: Ricoh mode (PPR x 1) 1: ITU-T mode (PPR x 4)	When using ECM, the machine will choose a slower modem rate after receiving PPR once (Ricoch mode) or four times (ITU-T mode). This bit is ineffective in V.34 communications.
5	Modem rate used for the next page after receiving a negative code (RTN or PIN) 0: No change 1: Fallback	1: The machine's tx modem rate will fall back before sending the next page if a negative code is received. This bit is ignored if ECM is being used.
6	V.8 protocol in manual transmission 0: Disabled 1: Enabled	1: The machine detects either ANSam or CED during manual transmission.
7	Not used	Do not change the setting.

Service
Tables

G3 Switch 04		SP No. 1-105-005
No	FUNCTION	COMMENTS
0 to 3	Training error detection threshold	0 - F (Hex); 0 - 15 bits If the number of error bits in the received TCF is below this threshold, the machine informs the sender that training has succeeded.
4-7	Not used	Do not change the settings.

G3 Switch 05		SP No. 1-105-006
No	FUNCTION	COMMENTS
0 to 3	Initial Tx modem rate Bit 3 2 1 0 Setting (bps) 0 0 0 1 2.4 k 0 0 1 0 4.8 k 0 0 1 1 7.2 k 0 1 0 0 9.6 k 0 1 0 1 12.0 k 0 1 1 0 14.4 k 0 1 1 1 16.8 k 1 0 0 0 19.2 k 1 0 0 1 21.6 k 1 0 1 0 24.0 k 1 0 1 1 26.4 k 1 1 0 0 28.8 k 1 1 0 1 31.2 k 1 1 1 0 33.6 k Other settings - Not used	These bits set the initial starting modem rate for transmission. Use the dedicated transmission parameters if you need to change this for specific receivers. If a modem rate 14.4 kbps or slower is selected, V.8 protocol should be disabled manually. Cross reference V.8 protocol on/off - G3 switch 03, bit2
4 to 5	Initial modem type for 9.6 k or 7.2 kbps. Bit 5 Bit 4 Setting 0 0 V.29 0 1 V.17 1 0 V.34 1 1 Not used	These bits set the initial modem type for 9.6 and 7.2 kbps, if the initial modem rate is set at these speeds.
6-7	Not used	Do not change the settings.

G3 Switch 06		SP No. 1-105-007
No	FUNCTION	COMMENTS
0 to 3	Initial Rx modem rate Bit 3 2 1 0 Setting (bps) 0 0 0 1 2.4 k 0 0 1 0 4.8 k 0 0 1 1 7.2 k 0 1 0 0 9.6 k 0 1 0 1 12.0 k 0 1 1 0 14.4 k 0 1 1 1 16.8 k 1 0 0 0 19.2 k 1 0 0 1 21.6 k 1 0 1 0 24.0 k 1 0 1 1 26.4 k 1 1 0 0 28.8 k 1 1 0 1 31.2 k 1 1 1 0 33.6 k Other settings - Not used	These bits set the initial starting modem rate for reception. Use a lower setting if high speeds pose problems during reception. If a modem rate 14.4 kbps or slower is selected, V.8 protocol should be disabled manually. Cross reference V.8 protocol on/off - G3 switch 03, bit2

G3 Switch 06		SP No. 1-105-007
No	FUNCTION	COMMENTS
4 to 7	<p>Modem types available for reception</p> <p>Bit 7 6 5 4 Setting</p> <p>0 0 0 1 V.27ter</p> <p>0 0 1 0 V.27ter, V.29</p> <p>0 0 1 1 V.27ter, V.29 V.33</p> <p>0 1 0 0 V.27ter, V.29, V.17/V.33</p> <p>0 1 0 1 V.27ter, V.29, V.17/V.33, V.34</p> <p>Other settings - Not used</p>	<p>The setting of these bits is used to inform the transmitting terminal of the available modem type for the machine in receive mode.</p> <p>If V.34 is not selected, V.8 protocol must be disabled manually.</p> <p>Cross reference V.8 protocol on/off - G3 switch 03, bit2</p>

G3 Switch 07		SP No. 1-105-008
No	FUNCTION	COMMENTS
0 to 1	<p>PSTN cable equalizer (tx mode: Internal)</p> <p>Bit 1 Bit 0 Setting</p> <p>0 0 None</p> <p>0 1 Low</p> <p>1 0 Medium</p> <p>1 1 High</p>	<p>Use a higher setting if there is signal loss at higher frequencies because of the length of wire between the modem and the telephone exchange.</p> <p>Use the dedicated transmission parameters for specific receivers.</p> <p>Also, try using the cable equalizer if one or more of the following symptoms occurs.</p> <ul style="list-style-type: none"> • Communication error • Modem rate fallback occurs frequently. <p>Note: This setting is not effective in V.34 communications.</p>
2 to 3	<p>PSTN cable equalizer (rx mode: Internal)</p> <p>Bit 3 Bit 2 Setting</p> <p>0 0 None</p> <p>0 1 Low</p> <p>1 0 Medium</p> <p>1 1 High</p>	<p>Use a higher setting if there is signal loss at higher frequencies because of the length of wire between the modem and the telephone exchange.</p> <p>Also, try using the cable equalizer if one or more of the following symptoms occurs.</p> <ul style="list-style-type: none"> • Communication error with error codes such as 0-20, 0-23, etc. • Modem rate fallback occurs frequently. <p>Note: This setting is not effective in V.34 communications.</p>
4	<p>PSTN cable equalizer (V.8/V.17 rx mode: External)</p> <p>0: Disabled</p> <p>1: Enabled</p>	<p>Keep this bit at "1".</p>
5	<p>PSTN cable equalizer (V.34 rx mode; External)</p>	<p>Keep this bit at "1".</p>
6-7	<p>Not used</p>	<p>Do not change the settings.</p>

Service Tables

G3 Switch 08 - Not used (do not change the settings)

G3 Switch 09		SP No. 1-105-010
No	FUNCTION	COMMENTS
0 to 1	ISDN cable equalizer (tx mode: Internal) Bit 1 Bit 0 Setting 0 0 None 0 1 Low 1 0 Medium 1 1 High	Use a higher setting if there is signal loss at higher frequencies because of the length of wire between the modem and the telephone exchange. Use the dedicated transmission parameters for specific receivers. Also, try using the cable equalizer if one or more of the following symptoms occurs. <ul style="list-style-type: none"> • Communication error • Modem rate fallback occurs frequently. Note: This setting is not effective in V.34 communications.
2 to 3	ISDN cable equalizer (rx mode: Internal) Bit 3 Bit 2 Setting 0 0 None 0 1 Low 1 0 Medium 1 1 High	Use a higher setting if there is signal loss at higher frequencies because of the length of wire between the modem and the telephone exchange. Also, try using the cable equalizer if one or more of the following symptoms occurs. <ul style="list-style-type: none"> • Communication error with error codes such as 0-20, 0-23, etc. • Modem rate fallback occurs frequently. Note: This setting is not effective in V.34 communications.
4	ISDN cable equalizer (V.8/V.17 rx mode: External) 0: Disabled 1: Enabled	Keep this bit at "0" in most cases.
5	ISDN cable equalizer (V.34 rx mode: External) 0: Disabled 1: Enabled	Keep this bit at "0" in most cases.
6-7	Not used	Do not change the settings.

G3 Switch 0A		SP No. 1-105-011
No	FUNCTION	COMMENTS
0 to 1	Maximum allowable carrier drop during image data reception Bit 1 Bit 0 Value (ms) 0 0 200 0 1 400 1 0 800 1 1 Not used	These bits set the acceptable modem carrier drop time. Try using a longer setting if error code 0-22 is frequent.

G3 Switch 0A		SP No. 1-105-011
No	FUNCTION	COMMENTS
2-3	Not used	Do not change the settings.
4	Maximum allowable frame interval during image data reception. 0: 5 s 1: 13 s	This bit set the maximum interval between EOL (end-of-line) signals and the maximum interval between ECM frames from the other end. Try using a longer setting if error code 0-21 is frequent.
5	Not used	Do not change the settings.
6	Reconstruction time for the first line in receive mode 0: 6 s 1: 12 s	When the sending terminal is controlled by a computer, there may be a delay in receiving page data after the local machine accepts set-up data and sends CFR. This is outside the T.30 recommendation. But, if this delay occurs, set this bit to 1 to give the sending machine more time to send data. Refer to error code 0-20. ITU-T T.30 recommendation: The first line should come within 5 s of CFR.
7	Not used	Do not change the settings.

G3 Switch 0B		SP No. 1-105-012
No	FUNCTION	COMMENTS
0	Protocol requirements: Europe 0: Disabled 1: Enabled	The machine does not automatically reset these bits for each country after a country code (System Switch 0F) is programmed. Change the required bits manually at installation.
1	Protocol requirements: Spain 0: Disabled 1: Enabled	
2	Protocol requirements: Germany 0: Disabled 1: Enabled	
3	Protocol requirements: France 0: Disabled 1: Enabled	
4	PTT requirements: Germany 0: Disabled 1: Enabled	
5	PTT requirements: France 0: Disabled 1: Enabled	
6	Not used	Do not change the settings.
7	DTS requirements : Germany 0: Disabled 1: Enabled	Change this bit manually if required.

G3 Switch 0C		SP No. 1-105-013
No	FUNCTION	COMMENTS
0	Pulse dialing method	P = Number of pulses sent out, N = Number dialed.
1	Bit 1 Bit 0 Setting	
	0 0 Normal(P=N)	
	0 1 Oslo (P=10 - N)	
	1 0 Sweden (N+1)	
	1 1 Not used	
2-7	Not used	Do not change the settings.

G3 Switch 0D		SP No. 1-105-014																								
No	FUNCTION	COMMENTS																								
0-1	Not used	Do not change the settings.																								
2 to 5	Data rate threshold during V.34 reception <table border="0"> <tr> <td>Bit</td> <td>5</td> <td>4</td> <td>3</td> <td>2</td> <td>Setting</td> </tr> <tr> <td></td> <td>0</td> <td>0</td> <td>0</td> <td>0</td> <td>Normal</td> </tr> <tr> <td></td> <td>0</td> <td>1</td> <td>1</td> <td>1</td> <td>Lower by one step</td> </tr> <tr> <td></td> <td>1</td> <td>1</td> <td>1</td> <td>1</td> <td>Lower by two steps</td> </tr> </table>	Bit	5	4	3	2	Setting		0	0	0	0	Normal		0	1	1	1	Lower by one step		1	1	1	1	Lower by two steps	The machine changes the modulation parameters in the MPh signal to lower the initial modem rate during V.34 reception. If this switch is set to "0111", the machine lowers the initial speed one step, for example, from 28,800 to 26,400 bps. This switch reduces transmission time if the machine frequently sends PPR signals during V.34 reception.
Bit	5	4	3	2	Setting																					
	0	0	0	0	Normal																					
	0	1	1	1	Lower by one step																					
	1	1	1	1	Lower by two steps																					
6	Not used	Do not change the settings.																								
7	B signal detection time for V.34 polling transmission 0: 75 ms (default setting) 1: 65 ms	Change this switch only when there are communication errors during V.34 polling transmission to a machine with a Panasonic modem.																								

G3 Switch 0E - Not used (do not change the settings)

G3 Switch 0F		SP No. 1-105-016
No	FUNCTION	COMMENTS
0	Alarm when an error occurred in Phase C or later 0: Disabled 1: Enabled	If the customer wants to hear an alarm after each error communication, change this bit to "1".
1	Alarm when the handset is off-hook at the end of communication 0: Disabled 1: Enabled	If the customer wants to hear an alarm if the handset is off-hook at the end of fax communication, change this bit to "1".
2-7	Not used	Do not change the settings.

4.2.6 G3-2 SWITCHES

These switches require an optional G3 interface unit.

G3-2 Switch 00			SP No. 1-106-001
No	FUNCTION	COMMENTS	
0-1	Monitor speaker during communication (tx and rx)	(0, 0): The monitor speaker is disabled all through the communication. (0, 1): The monitor speaker is on up to phase B in the T.30 protocol. (1, 0): Used for testing. The monitor speaker is on all through the communication. Make sure that you reset these bits after testing.	
	Bit 1 Bit 0 Setting		
	0 0 Disabled		
	0 1 Up to Phase B		
	1 0 All the time		
1 1 Not used			
2	Monitor speaker during memory transmission 0: Disabled 1: Enabled	1: The monitor speaker is enabled during memory transmission.	
3-6	Not used	Do not change the settings.	

G3-2 Switch 01			SP No. 1-106-002
No	FUNCTION	COMMENTS	
0-3	Not used	Do not change the settings.	
4	DIS frame length 0: 10 bytes 1: 4 bytes	1: The bytes in the DIS frame after the 4th byte will not be transmitted (set to 1 if there are communication problems with PC-based faxes which cannot receive the extended DIS frames).	
5	Not used	Do not change the setting.	
6	CED/ANSam transmission 0: Disabled 1: Enabled	Do not change this setting, unless the communication problem is caused by the CED/ANSam transmission.	
7	Not used	Do not change the setting.	

G3-2 Switch 02			SP No. 1-106-003
No	FUNCTION	COMMENTS	
0	G3 protocol mode used 0: Standard and non-standard 1: Standard only	Change this bit to 1 only when the other end can only communicate with machines that send T.30-standard frames only. 1: Disables NSF/NSS signals (these are used in non-standard mode communication)	
1-4	Not used	Do not change the settings.	
5	Use of modem rate history for transmission using Quick/Speed Dials 0: Disabled 1: Enabled	0: Communications using Quick/Speed Dials always start from the highest modem rate. 1: The machine refers to the modem rate history for communications with the same machine when determining the most suitable rate for the current communication.	
6	AI short protocol (transmission and reception) 0: Disabled 1: Enabled	Refer to Appendix B in the Group 3 Facsimile Manual for details about AI Short Protocol.	
7	Short preamble 0: Disabled 1: Enabled	Refer to Appendix B in the Group 3 Facsimile Manual for details about Short Preamble.	

G3-2 Switch 03		SP No. 1-106-004
No	FUNCTION	COMMENTS
0	DIS detection number (Echo countermeasure) 0: 1 1: 2	0: The machine will hang up if it receives the same DIS frame twice. 1: Before sending DCS, the machine will wait for the second DIS which is caused by echo on the line.
1	Not used	Do not change the settings.
2	V.8 protocol 0: Disabled 1: Enabled	0: V.8/V.34 communications will not be possible. Note: Do not set to 0 unless the line condition is always bad enough to slow down the data rate to 14.4 kbps or lower.
3	ECM frame size 0: 256 bytes 1: 64 bytes	Keep this bit at "0" in most cases.
4	CTC transmission conditions 0: After one PPR signal received 1: After four PPR signals received (ITU-T standard)	0: When using ECM in non-standard (NSF/NSS) mode, the machine sends a CTC to drop back the modem rate after receiving a PPR, if the following condition is met in communications at 14.4, 12.0, 9.6, and 7.2 kbps. $\sqrt{N_{\text{Transmit}} \leq N_{\text{Resend}}}$ N _{Transmit} - Number of transmitted frames N _{Resend} - Number of frames to be retransmitted 1: When using ECM, the machine sends a CTC to drop back the modem rate after receiving four PPRs. PPR, CTC: These are ECM protocol signals. This bit is not effective in V.34 communications.
5	Modem rate used for the next page after receiving a negative code (RTN or PIN) 0: No change 1: Fallback	1: The machine's tx modem rate will fall back before sending the next page if a negative code is received. This bit is ignored if ECM is being used.
6	Not used	Do not change the settings.
7	Not used	Do not change the settings.

G3-2 Switch 04		SP No. 1-106-005
No	FUNCTION	COMMENTS
0 to 3	Training error detection threshold	0 - F (Hex); 0 - 15 bits If the number of error bits in the received TCF is below this threshold, the machine informs the sender that training has succeeded.
4-7	Not used	Do not change the settings.

G3-2 Switch 05		SP No. 1-106-006
No	FUNCTION	COMMENTS
0 to 3	Initial Tx modem rate Bit 3 2 1 0 Setting (bps) 0 0 0 1 2.4 k 0 0 1 0 4.8 k 0 0 1 1 7.2 k 0 1 0 0 9.6 k 0 1 0 1 12.0 k 0 1 1 0 14.4 k 0 1 1 1 16.8 k 1 0 0 0 19.2 k 1 0 0 1 21.6 k 1 0 1 0 24.0 k 1 0 1 1 26.4 k 1 1 0 0 28.8 k 1 1 0 1 31.2 k 1 1 1 0 33.6 k Other settings - Not used	These bits set the initial starting modem rate for transmission. Use the dedicated transmission parameters if you need to change this for specific receivers. If a modem rate 14.4 kbps or slower is selected, V.8 protocol should be disabled manually. Cross reference V.8 protocol on/off - SG3 switch 03, bit2
4 to 5	Initial modem type for 9.6 k or 7.2 kbps. Bit 5 Bit 4 Setting 0 0 V.29 0 1 V.17 1 0 V.34 1 1 Not used	These bits set the initial modem type for 9.6 and 7.2 kbps, if the initial modem rate is set at these speeds.
6-7	Not used	Do not change the settings.

Service
Tables

G3-2 Switch 06		SP No. 1-106-007
No	FUNCTION	COMMENTS
0 to 3	Initial Rx modem rate Bit 3 2 1 0 Setting (bps) 0 0 0 1 2.4 k 0 0 1 0 4.8 k 0 0 1 1 7.2 k 0 1 0 0 9.6 k 0 1 0 1 12.0 k 0 1 1 0 14.4 k 0 1 1 1 16.8 k 1 0 0 0 19.2 k 1 0 0 1 21.6 k 1 0 1 0 24.0 k 1 0 1 1 26.4 k 1 1 0 0 28.8 k 1 1 0 1 31.2 k 1 1 1 0 33.6 k Other settings - Not used	These bits set the initial starting modem rate for reception. Use a lower setting if high speeds pose problems during reception. If a modem rate 14.4 kbps or slower is selected, V.8 protocol should be disabled manually. Cross reference V.8 protocol on/off - SG3 switch 03, bit2

G3-2 Switch 06		SP No. 1-106-007
No	FUNCTION	COMMENTS
4 to 7	<p>Modem types available for reception</p> <p>Bit 7 6 5 4 Setting</p> <p>0 0 0 1 V.27ter</p> <p>0 0 1 0 V.27ter, V.29</p> <p>0 0 1 1 V.27ter, V.29 V.33</p> <p>0 1 0 0 V.27ter, V.29, V.17/V.33</p> <p>0 1 0 1 V.27ter, V.29, V.17/V33, V.34</p> <p>Other settings - Not used</p>	<p>The setting of these bits is used to inform the transmitting terminal of the available modem type for the machine in receive mode.</p> <p>If V.34 is not selected, V.8 protocol must be disabled manually.</p> <p>Cross reference V.8 protocol on/off - SG3 switch 03, bit2</p>

G3-2 Switch 07		SP No. 1-106-008
No	FUNCTION	COMMENTS
0 to 1	<p>PSTN cable equalizer (tx mode: Internal)</p> <p>Bit 1 Bit 0 Setting</p> <p>0 0 None</p> <p>0 1 Low</p> <p>1 0 Medium</p> <p>1 1 High</p>	<p>Use a higher setting if there is signal loss at higher frequencies because of the length of wire between the modem and the telephone exchange.</p> <p>Use the dedicated transmission parameters for specific receivers.</p> <p>Also, try using the cable equalizer if one or more of the following symptoms occurs.</p> <ul style="list-style-type: none"> • Communication error • Modem rate fallback occurs frequently. <p>Note: This setting is not effective in V.34 communications.</p>
2 to 3	<p>PSTN cable equalizer (rx mode: Internal)</p> <p>Bit 3 Bit 2 Setting</p> <p>0 0 None</p> <p>0 1 Low</p> <p>1 0 Medium</p> <p>1 1 High</p>	<p>Use a higher setting if there is signal loss at higher frequencies because of the length of wire between the modem and the telephone exchange.</p> <p>Also, try using the cable equalizer if one or more of the following symptoms occurs.</p> <ul style="list-style-type: none"> • Communication error with error codes such as 0-20, 0-23, etc. • Modem rate fallback occurs frequently. <p>Note: This setting is not effective in V.34 communications.</p>
4	<p>PSTN cable equalizer (V.8/V.17 rx mode: External)</p> <p>0: Disabled</p> <p>1: Enabled</p>	<p>Keep this bit at "1".</p>
5	<p>PSTN cable equalizer (V.34 rx mode; External)</p>	<p>Keep this bit at "1".</p>
6-7	Not used	Do not change the settings.

G3-2 Switch 08 - Not used (do not change the settings)
G3-2 Switch 09 - Not used (do not change the settings)

G3-2 Switch 0A		SP No. 1-106-011
No	FUNCTION	COMMENTS
0 1	Maximum allowable carrier drop during image data reception Bit 1 Bit 0 Value (ms) 0 0 200 0 1 400 1 0 800 1 1 Not used	These bits set the acceptable modem carrier drop time. Try using a longer setting if error code 0-22 is frequent.
2-3	Not used	Do not change the settings.
4	Maximum allowable frame interval during image data reception. 0: 5 s 1: 13 s	This bit set the maximum interval between EOL (end-of-line) signals and the maximum interval between ECM frames from the other end. Try using a longer setting if error code 0-21 is frequent.
5	Not used	Do not change the settings.
6	Reconstruction time for the first line in receive mode 0: 6 s 1: 12 s	When the sending terminal is controlled by a computer, there may be a delay in receiving page data after the local machine accepts set-up data and sends CFR. This is outside the T.30 recommendation. But, if this delay occurs, set this bit to 1 to give the sending machine more time to send data. Refer to error code 0-20. ITU-T T.30 recommendation: The first line should come within 5 s of CFR.
7	Not used	Do not change the settings.

Service
Tables

G3-2 Switch 0B		SP No. 1-106-012
No	FUNCTION	COMMENTS
0	Protocol requirements: Europe 0: Disabled 1: Enabled	The machine does not automatically reset these bits for each country after a country code (System Switch 0F) is programmed. Change the required bits manually at installation.
1	Protocol requirements: Spain 0: Disabled 1: Enabled	
2	Protocol requirements: Germany 0: Disabled 1: Enabled	
3	Protocol requirements: France 0: Disabled 1: Enabled	
4	PTT requirements: Germany 0: Disabled 1: Enabled	
5	PTT requirements: France 0: Disabled 1: Enabled	
6	Not used	Do not change the settings.
7	Not used	Do not change the settings.

G3-2 Switch 0C		SP No. 1-106-013
No	FUNCTION	COMMENTS
0	Pulse dialing method	P = Number of pulses sent out, N = Number dialed.
1	Bit 1 Bit 0 Setting	
	0 0 Normal(P=N)	
	0 1 Oslo (P=10 - N)	
	1 0 Sweden (N+1)	
	1 1 Not used	
2-7	Not used	Do not change the settings.

G3-2 Switch 0D - Not used (do not change the settings)
G3-2 Switch 0E - Not used (do not change the settings)
G3-2 Switch 0F - Not used (do not change the settings)

4.2.7 G4 INTERNAL SWITCHES

G4 Internal Switch 00		
No.	FUNCTION	COMMENTS
0-7	Country code	
	Bit 4 3 2 1 0 Country	
	0 0 0 0 1 Germany (1TR6 mode)	
	0 0 0 1 0 Universal (Europe Euro ISDN)	
	1 0 0 0 1 USA	
Note: In Germany, use the Universal setting for the Euro ISDN lines.		

G4 Internal Switch 01 - Not used (do not change these settings)

G4 Internal Switch 02 - Not used (do not change these settings)

G4 Internal Switch 03		
No.	FUNCTION	COMMENTS
0	Amount of protocol dump data in one protocol dump list 0: Last communication only 1: Up to the limit of the memory area for protocol dumping	Change this bit to 0 if you want to have a protocol dump list of the last communication only. This bit is only effective for the dump list D + Bch1.
1-7	Not used	Do not change these settings.

Service
Tables

G4 Internal Switch 04		
No.	FUNCTION	COMMENTS
0-2	Not used	Do not change these settings.
3	Auto data rate change for transmission (64 kbps to 56 kbps) 0: On 1: Off	0: The machine automatically changes the transmission data rate from 64 kbps to 56 kbps after 3 s if the other end did not accept the call. This is to cope with 56 kbps networks in the USA. Normally, keep this bit at 0.
4	Auto data rate change for reception (64 kbps to 56 kbps) 0: Off 1: On	1: The machine automatically changes the reception data after 6 s. Change this bit to 1 only when there is a communication error where the other terminal informs 64 kbps in the SETUP signal although it is actually 56 kbps.
5-7	Not used	Do not change these settings.

G4 Internal Switch 05		
No.	FUNCTION	COMMENTS
0-1	Not used	Do not change these settings.
2	Protocol ID check 0: Yes 1: No	The Protocol ID is in the CR packet.
3-7	Not used	Do not change these settings.

G4 Internal Switch 06 - Not used (do not change these settings)
G4 Internal Switch 07 - Not used (do not change these settings)
G4 Internal Switch 08 - Not used (do not change these settings)
G4 Internal Switch 09 - Not used (do not change these settings)
G4 Internal Switch 0A - Not used (do not change these settings)
G4 Internal Switch 0B - Not used (do not change these settings)
G4 Internal Switch 0C - Not used (do not change these settings)
G4 Internal Switch 0D - Not used (do not change these settings)
G4 Internal Switch 0E - Not used (do not change these settings)
G4 Internal Switch 0F - Not used (do not change these settings)

G4 Internal Switch 10 (Dch. Layer 1)		
No.	FUNCTION	COMMENTS
0-5	Not used	Do not change these settings.
6	INFO1 signal resend 0: Resend 1: No resend	0: Some DSUs may not reply to the INFO1 signal with INFO2, if there is noise in the INFO1 signal accidentally. Try changing this bit to 0, to resend INFO1 before the machine displays "CHECK INTERFACE".
7	Not used	Do not change these settings.

G4 Internal Switch 11 (Dch. Layer 2)		
No.	FUNCTION	COMMENTS
0	Not used	Do not change these settings.
1	Type of TEI used 0: Dynamic TEI 1: Static TEI	This is normally fixed at 0. However, some networks may require this bit to be set at 1 (see below). In this case, you may have to change the values of bits 2 to 7.
2-7	Static TEI value	Store the lowest bit of the TEI at bit 7 and the highest bit of the TEI at bit 2. Example: If the static TEI is 011000, set bits 3 and 4 to 1 and bits 2, 5, 6, and 7 to 0.

G4 Internal Switch 12 - Not used (do not change these settings)
--

G4 Internal Switch 13: D channel layer 3 (Attachment IE in S: SETUP)		
No.	FUNCTION	COMMENTS
0	Not used	Do not change these settings.
1	Information transfer capability shift down to retry transmission 0: Shift down procedure disabled (Default) 1: Shift down and retry the call	1: The machine changes the ISDN G3 information transfer capability informed in the [SETUP] signal to "Speech" from "3.1 kHz audio" or to "3.1 kHz audio" from "Speech" automatically and retries the transmission. The information transfer capability used in the first try is determined by the setting of G4 internal bit switch 14 bit 0. This switch is effective with some types of exchangers and T/As where they only accept calls with information transfer capability "Speech".
2	Attachment of calling ID and subaddress 0: No 1: Yes	Normally, this bit should be at 0, because most networks add the calling ID and subaddress to the SETUP signal to the receiver. However, some networks may require the machine to add this ID (and/or subaddress). Only in this case should this bit be at 1.
3	Attachment of the Lower Layer Capabilities 0: No 1: Yes	This bit determines whether Lower Layer Capabilities are informed in the [SETUP] signal. Keep this bit at 0 in most cases.
4	Attachment of the Higher Layer Capabilities 0: Yes 1: No	This bit determines whether Higher Layer Capabilities are informed in the [SETUP] signal or not. Keep this bit at 0 in most cases.
5	Attachment of the channel information element (CONN) 0: No 1: Yes	Keep this bit at 0 in most cases.
6	Attachment of the Higher Layer Capabilities for ISDN G3 transmission 0: Same as the bit 4 setting 1: Not attached	This bit determines whether Higher Layer Capabilities are informed in the [SETUP] signal for ISDN G3 transmission. This switch is effective in coping with communication problems with some types of T/A and PBX that do not respond to Higher Layer Capability "G3". When this bit is set to 0, the setting depends on the setting of bit 4. Keep this bit at 1 in most cases.

G4 Internal Switch 13: D channel layer 3 (Attachment IE in S: SETUP)		
No.	FUNCTION	COMMENTS
7	Condition for fallback from G4 to G3 0: Refer to the CPS code setting 1: Fallback in response to any CPS code	0: Fallback occurs when a CPS code is the same as the CPS code settings specified by G4 internal switches 17, 18, 1A, 1B, and 1C. If you wish to enable fallback when any CPS code is detected, set this bit to "1". This switch is effective in coping with fallback problems where the CPS code does not match those specified in the ITU-T recommendation.

G4 Internal Switch 14: D channel layer 3 (Selection IE in S: SETUP)		
No.	FUNCTION	COMMENTS
0	ISDN G3 information transfer capability 0: 3.1 kHz audio 1: Speech	In tx mode, this determines the information transfer capability informed in the [SETUP] message. In rx mode, this determines the information transfer capability that the machine can use to receive a call. Set this bit to 1 if the ISDN does not support 3.1 kHz audio.
1-2	Not used	Do not change these settings.
3-4	Channel selection in [SETUP] in tx mode Bit 4 3 Setting 0 0 Any channel 0 1 B1 channel 1 0 B2 channel 1 1 Not used	Any channel: When this is informed to the exchanger, the exchanger will select either B1 or B2.
5	Called ID mapping 0: Called party number 1: Keypad facility	0: Called ID is mapped to the called party number. 1: Called ID is mapped to the keypad facility. Note that the subaddress is not mapped. On the 5ESS network (USA), set it to 1.
6	Numbering plan for the called party number 0: Unknown 1: E.164	E.164: This may be used in Sweden if an AXE10 exchanger is fitted with old software, and in Australia. Unknown: This is the normal setting.
7	Subaddress coding type 0: IA5 (NSAP) 1: BCD (ISO8348)	This is normally kept at 0. However, some networks require this bit to be at 1.

G4 Internal Switch 15: D channel layer 3 (Judgement R: MSG)		
No.	FUNCTION	COMMENTS
0	Action when receiving [SETUP] signal containing no called subaddress 0: A reply is sent 1: No reply is sent	This bit depends on user requirements. If it is at 1, communication will be halted if the other terminal has not input the subaddress.
1-4	Not used	Do not change the settings
5	Global call reference 0: Ignored 1: Global call number is used	Global call reference means 'call reference value = 0'. This bit determines how to deal with such an incoming call if received from the network. Keep this bit at 1 in Germany 1TR6.
6-7	Not used	Do not change these settings.

G4 Internal Switch 16: D channel layer 3 (Approval)		
No.	FUNCTION	COMMENTS
0-1	Answer delay time Bit 1 0 Setting 0 0 No delay 0 1 1.0 s delayed (1TR6) 1 0 0.5 s delayed 1 1 Not used	In some countries, a time delay to answer a call is required. Otherwise, use this switch as follows: If the machine is connected to the same bus from the DSU as a model K200 is connected, the machine receives most of the calls because the response time to a call is faster than the K200. If the customer wants the K200 to receive most of the calls, adjust the response time using these bits. If the customer does not want one machine to receive most of the calls, use subaddresses to identify each terminal.
2	Action when receiving [SETUP] signal containing user-specific called party subaddress 0: Ignores the call 1: Receives the call	Normally, the 3rd octet of called party subaddress information in the [SETUP] signal is set to NSAP. However, some networks may add "user-specific" subaddress to the [SETUP] signal, and the result of this is that the machine won't answer the call if a subaddress is specified. So, change this bit to 1 to let the machine receive the call if the machine is connected to such a network.
3-4	Not used	Do not change these settings.
5	Indicated bearer capabilities 0: 56 kbps 1: 64 kbps	1: 64 kbps calling is indicated in the Bearer Capabilities, but communication is at 56 k. Use this bit if the machine is connected to a network which does not accept a 56 kbps data transfer rate as a bearer capability.
6	Not used	Do not change these settings.

Service Tables

G4 Internal Switch 16: D channel layer 3 (Approval)		
No.	FUNCTION	COMMENTS
7	Transfer capabilities (SI) informed in 1TR6 ISDN G3 transmission 0: G3 Fax 1: Analog	This bit determines whether transfer capabilities informed in the Service Indicator for 1TR6 ISDN G3 transmission. This switch is effective in coping with communication problems with some types of T/A and PBXs. Normally keep this bit at 1 in Germany 1TR6.

G4 Internal Switch 17: CPS Code Used for G4 to G3 Fallback - 1		
No.	FUNCTION	COMMENTS
0-6	Condition for fallback from G4 to G3 Bits 0 to 6 of bit switch 17 contain a CPS code, and bits 0 to 6 of bit switch 18 contain another CPS code. If a CPS code is received which is the same as either of these, communication will fall back from ISDN G4 mode to ISDN G3 mode. The CPS codes must be the same as those specified in table 4-13 of ITU-T recommendation Q.931. Examples: Bit 6 5 4 3 2 1 0 1 0 0 0 0 0 1 CPS code 65 1 0 1 1 0 0 0 CPS code 88	For the codes in bits 0 to 6 of bit switches 17 and 18 to be recognized, bit 7 of bit switch 17 must be 1. Also, bit 0 of the Communication Switch 07 must be at 0, or Fallback from G4 to G3 will be disabled.
7	0: Fallback occurs on receipt of any of the following CPS codes: Universal (Euro ISDN) - #3, #18, #57, #58, # 63, # 65, #79, #88, and #127 Germany 1TR6 mode - #3, #53, #58, and #90 Others - #3, #65, and #88 1: Fallback from G4 to G3 occurs on receipt any of above CPS codes or one of the CPS codes programmed in bit switch 17, 18, 1A, 1B, or 1C	This bit determines whether fallback from G4 to G3 occurs on receipt of one of the CPS codes programmed in bit switch 17 or 18, or on receipt of a certain standard code.

G4 Internal Switch 18: CPS Code Used for G4 to G3 Fallback - 2		
No.	FUNCTION	COMMENTS
0-6	Condition for fallback from G4 to G3 See the explanation for bits 0 to 6 of bit switch 17	
7	0: Fallback occurs on receipt of the CPS code set, which is specified by the country code setting. 1: Fallback occurs on receipt of the Universal CPS code set (#3, #18, #57, #58, # 63, # 65, #79, #88, and #127) even if another country code is programmed. If bit switch 17 bit 7 is "1", fallback occurs on receipt of the Universal CPS code set or one of the CPS codes programmed in bit switches 17, 18, 1A, 1B, or 1C.	This bit helps to choose the CPS code set for G4 to G3 fallback.

G4 to G3 fallback

Bit 0 of Communication Switch 07 must be at 0, or fallback from G4 to G3 will be disabled.

The CPS codes for which fallback occurs are decided as follows.

- G4 bit switch 17, bit 7 - If set to "0", fallback occurs on receipt of a code from a set that depends on the country code. If set to "1", fallback occurs for the 5 CPS codes programmed in bits 0 to 6 of G4 bit switches 17, 18, 1A, 1B, and 1C, in addition to the country code set.

Note that if G4 bit switch 18, bit 7 is set to "1", the CPS code set that is used is always the Universal set, regardless of the country code setting.

G4 Internal Switch 19		
No.	FUNCTION	COMMENTS
0	Permanence of the link 0: Set/released each LAPD call 1: Permanent	Keep this at 1 in the USA. In other areas, this bit is normally 0, depending on network requirements.
1	Channel used in ISDN L2 (64k) mode 0: B1 1: B2	When making an ISDN L2 back-to-back test, you can select either the B1 or B2 channel with this bit switch.
2-7	Not used	Do not change the factory settings.

Service Tables

G4 Internal Switch 1A: CPS Code Used for G4 to G3 Fallback - 3		
No.	FUNCTION	COMMENTS
0-6	Condition for fallback from G4 to G3 See the explanation for bits 0 to 6 of bit switch 17.	
7	Not used	Do not change this setting.

G4 Internal Switch 1B: CPS Code Used for G4 to G3 Fallback - 4		
No.	FUNCTION	COMMENTS
0-6	Condition for fallback from G4 to G3 See the explanation for bits 0 to 6 of bit switch 17.	
7	Not used	Do not change this setting.

G4 Internal Switch 1C: CPS Code Used for G4 to G3 Fallback - 5		
No.	FUNCTION	COMMENTS
0-6	Condition for fallback from G4 to G3 See the explanation for bits 0 to 6 of bit switch 17.	
7	Not used	Do not change this setting.

G4 Internal Switch 1D - Not used (do not change these settings)		
G4 Internal Switch 1E - Not used (do not change these settings)		
G4 Internal Switch 1F - Not used (do not change these settings)		

4.2.8 G4 PARAMETER SWITCHES

G4 Parameter Switch 00		
No.	FUNCTION	COMMENTS
0-2	Network type Bit 2 1 0 Type x 0 0 Circuit switched ISDN Other settings: Not used	Do not change the default setting.
3-7	Not used	Do not change the default settings.

G4 Parameter Switch 01		
No.	FUNCTION	COMMENTS
0	Voice coding 0: μ law 1: A law	0: This setting is used in USA. 1: This setting is used in Europe and Asia.
1	Action when [SETUP] signal without HLC is received 0: Respond to the call 1: Not respond to the call	If there are several TEs on the same bus and the machine responds to calls for another TE, the call may be without HLC information. Identify the type of calling terminal and change this bit to 1 if the caller is not a fax machine.
2-6	Not used	Do not change these settings.
7	Signal attenuation for G3 fax signals received from ISDN line (-6dB) 0: Off 1: On	0: If an analog signal comes over digital line, the signal level after decoding by the TE is theoretically the same as the level at the entrance to the digital line. However, this sometimes causes the received signal level to be too high at the received end. In this case, set this bit to 1 to adjust the attenuation level.

G4 Parameter Switch 02		
No.	FUNCTION	COMMENTS
0-1	Data rate (kbps) Bit 1 0 Setting 0 0 64 kbps 0 1 56 kbps	Other settings: Not used
2-7	Not used	Do not change these settings.

G4 Parameter Switch 03 - Not used (do not change these settings)
G4 Parameter Switch 04 - Not used (do not change these settings)

G4 Parameter Switch 05		
No.	FUNCTION	COMMENTS
0-3	Not used	Do not change these settings.
4	B-channel T3 timer 0: 30s 1: 57s	1: This switch is useful when used in combination with the Communication Bit SW 07 bit 4. This is to cope with communication problems where G4 communication fails on the ISDN B-channel. Normally keep this bit at 1.
5-7	Not used	Do not change these settings.

G4 Parameter Switch 06		
No.	FUNCTION	COMMENTS
0	Layer 3 protocol 0: ISO8208 1: T.70NULL	Set this bit to match the type of layer 3 signaling used by the ISDN. The dedicated parameters have the same setting for specific destinations. Normally keep this bit at 0.
1-7	Not used	Do not change these settings.

G4 Parameter Switch 07		
No.	FUNCTION	COMMENTS
0-3	Packet size Bit 3 2 1 0 Value 0 1 1 1 128 1 0 0 0 256 1 0 0 1 512 1 0 1 0 1024 1 0 1 1 2048	This value is sent in the CR packet. This value must match the value stored in the other terminal, or communication will stop (CI will be returned). If the other end returns CI, check the value of the packet window size with the other party. Note that this value must be the same as the value programmed for the transport block size (G4 Parameter Switch 0B, bits 0 to 3). Normally, do not change the default setting.
4-7	Not used	Do not change these settings.

G4 Parameter Switch 08		
No.	FUNCTION	COMMENTS
0-3	Packet window size Bit 3 2 1 0 Value 0 0 0 1 1 0 0 1 0 2 and so on until 1 1 1 1 15	This is the maximum number of unacknowledged packets that the machine can send out before having to pause and wait for an acknowledgement from the other end. Normally this should be kept at 7.
4-7	Not used	Do not change these settings.

G4 Parameter Switch 09 - Not used (do not change these settings)
G4 Parameter Switch 0A - Not used (do not change these settings)

G4 Parameter Switch 0B		
No.	FUNCTION	COMMENTS
0-3	Transport block size	This value must match the value set in the other terminal. Note that this value must be the same as the value programmed for the packet size (G4 Parameter Switch 7, bits 0 to 3). Also, the transport block size is limited by the amount of memory in the remote terminal. Normally, do not change the default setting.
	Bit 3 2 1 0 Value	
	0 1 1 1 128	
	1 0 0 0 256	
	1 0 0 1 512	
	1 0 1 0 1024	
4-7	Not used	Do not change these settings.

G4 Parameter Switch 0C - Not used (do not change these settings)

G4 Parameter Switch 0D		
No.	FUNCTION	COMMENTS
0-1	Back-to-back test mode	When doing a back-to-back test or doing a demonstration without a line simulator, use these bits to set up one of the machines in TE mode, and the other in NT mode Please note that this machine can only be set to TE mode. After the test, return both bits to 0. See "Back-to-back Testing" in the Troubleshooting section for full details.
	Bit 1 0 Setting	
	0 0 Off	
	1 0 ISDN L2 test mode (TE mode)	
	Other settings - Not used	
2-7	Not used	Do not change these settings.

G4 Parameter Switch 0E - Not used (do not change these settings)
G4 Parameter Switch 0F - Not used (do not change these settings)

4.3 NCU PARAMETERS

The following tables give the RAM addresses and the parameter calculation units that the machine uses for ringing signal detection and automatic dialing. The factory settings for each country are also given. Most of these must be changed by RAM read/write (SP2-102), but some can be changed using NCU Parameter programming (SP2-103, 104 and 105); if SP2-103, 104 and 105 can be used, this will be indicated in the Remarks column. The RAM is programmed in hex code unless (BCD) is included in the Unit column.

NOTE: The following addresses describe settings for the standard NCU.
Change the fourth digit from "5" to "6" (e.g. 680500 to 680600) for the settings for the first optional G3 interface unit.

Address	Function	Unit	Remarks
680500	Country/Area code for NCU parameters		Use the Hex value to program the country/area code directly into this address, or use the decimal value to program it using SP2-103-001
		Country/Area	Decimal Hex
		France	00 00
		Germany	01 01
		UK	02 02
		Italy	03 03
		Austria	04 04
		Belgium	05 05
		Denmark	06 06
		Finland	07 07
		Ireland	08 08
		Norway	09 09
		Sweden	10 0A
		Switzerland	11 0B
		Portugal	12 0C
		Holland	13 0D
		Spain	14 0E
		Israel	15 0F
		USA	17 11
		Asia	18 12
		Hong Kong	20 14
		South Africa	21 15
		Australia	22 16
		New Zealand	23 17
		Singapore	24 18
		Malaysia	25 19
		China	26 1A
		Taiwan	27 1B
		Korea	28 1C
		Greece	33 21
		Hungary	34 22
		Czech	35 23
		Poland	36 24

Service
Tables

Address	Function	Unit	Remarks
680501	Line current detection time	20 ms	Line current detection is disabled. Line current is not detected if 680501 contains FF.
680502	Line current wait time		
680503	Line current drop detect time		
680504	PSTN dial tone frequency upper limit (high byte)	Hz (BCD)	If both addresses contain FF(H), tone detection is disabled.
680505	PSTN dial tone frequency upper limit (low byte)		
680506	PSTN dial tone frequency lower limit (high byte)	Hz (BCD)	If both addresses contain FF(H), tone detection is disabled.
680507	PSTN dial tone frequency lower limit (low byte)		
680508	PSTN dial tone detection time	20 ms	If 680508 contains FF(H), the machine pauses for the pause time (address 68050D / 68050E). Italy: See Note 2.
680509	PSTN dial tone reset time (LOW)		
68050A	PSTN dial tone reset time (HIGH)		
68050B	PSTN dial tone continuous tone time		
68050C	PSTN dial tone permissible drop time		
68050D	PSTN wait interval (LOW)		
68050E	PSTN wait interval (HIGH)		
68050F	PSTN ring-back tone detection time	20 ms	Detection is disabled if this contains FF.
680510	PSTN ring-back tone off detection time	20 ms	
680511	PSTN detection time for silent period after ring-back tone detected (LOW)	20 ms	
680512	PSTN detection time for silent period after ring-back tone detected (HIGH)	20 ms	
680513	PSTN busy tone frequency upper limit (high byte)	Hz (BCD)	If both addresses contain FF(H), tone detection is disabled.
680514	PSTN busy tone frequency upper limit (low byte)		
680515	PSTN busy tone frequency lower limit (high byte)	Hz (BCD)	If both addresses contain FF(H), tone detection is disabled.
680516	PSTN busy tone frequency lower limit (low byte)		
680517	PABX dial tone frequency upper limit (high byte)	Hz (BCD)	If both addresses contain FF(H), tone detection is disabled.
680518	PABX dial tone frequency upper limit (low byte)		
680519	PABX dial tone frequency lower limit (high byte)	Hz (BCD)	If both addresses contain FF(H), tone detection is disabled.
68051A	PABX dial tone frequency lower limit (low byte)		

Address	Function	Unit	Remarks																				
68051B	PABX dial tone detection time	20 ms	If 68051B contains FF, the machine pauses for the pause time (680520 / 680521).																				
68051C	PABX dial tone reset time (LOW)																						
68051D	PABX dial tone reset time (HIGH)																						
68051E	PABX dial tone continuous tone time																						
68051F	PABX dial tone permissible drop time																						
680520	PABX wait interval (LOW)																						
680521	PABX wait interval (HIGH)																						
680522	PABX ringback tone detection time	20 ms	If both addresses contain FF(H), tone detection is disabled.																				
680523	PABX ringback tone off detection time	20 ms																					
680524	PABX detection time for silent period after ringback tone detected (LOW)	20 ms	If both addresses contain FF(H), tone detection is disabled.																				
680525	PABX detection time for silent period after ringback tone detected (HIGH)	20 ms																					
680526	PABX busy tone frequency upper limit (high byte)	Hz (BCD)	If both addresses contain FF(H), tone detection is disabled.																				
680527	PABX busy tone frequency upper limit (low byte)																						
680528	PABX busy tone frequency lower limit (high byte)	Hz (BCD)	If both addresses contain FF(H), tone detection is disabled.																				
680529	PABX busy tone frequency lower limit (low byte)																						
68052A	Busy tone ON time: range 1	20 ms																					
68052B	Busy tone OFF time: range 1																						
68052C	Busy tone ON time: range 2																						
68052D	Busy tone OFF time: range 2																						
68052E	Busy tone ON time: range 3																						
68052F	Busy tone OFF time: range 3																						
680530	Busy tone ON time: range 4																						
680531	Busy tone OFF time: range 4																						
680532	Busy tone continuous tone detection time																						
680533	<p>Busy tone signal state time tolerance for all ranges, and number of cycles required for detection (a setting of 4 cycles means that ON-OFF-ON or OFF-ON-OFF must be detected twice).</p> <p>Tolerance (\pm)</p> <table border="0"> <tr> <td>Bit</td> <td>1</td> <td>0</td> <td></td> </tr> <tr> <td></td> <td>0</td> <td>0</td> <td>75% Bits 2 and 3 must always</td> </tr> <tr> <td></td> <td>0</td> <td>1</td> <td>50% be kept at 0.</td> </tr> <tr> <td></td> <td>1</td> <td>0</td> <td>25%</td> </tr> <tr> <td></td> <td>1</td> <td>1</td> <td>12.5%</td> </tr> </table> <p>Bits 7, 6, 5, 4 - number of cycles required for cadence detection</p>			Bit	1	0			0	0	75% Bits 2 and 3 must always		0	1	50% be kept at 0.		1	0	25%		1	1	12.5%
Bit	1	0																					
	0	0	75% Bits 2 and 3 must always																				
	0	1	50% be kept at 0.																				
	1	0	25%																				
	1	1	12.5%																				
680534	International dial tone frequency upper limit (high byte)	Hz (BCD)	If both addresses contain FF(H), tone detection is disabled.																				
680535	International dial tone frequency upper limit (low byte)																						

**Service
Tables**

Address	Function	Unit	Remarks
680536	International dial tone frequency lower limit (high byte)	Hz (BCD)	If both addresses contain FF(H), tone detection is disabled.
680537	International dial tone frequency lower limit (low byte)		
680538	International dial tone detection time	20 ms	If 680538 contains FF, the machine pauses for the pause time (68053D / 68053E). Belgium: See Note 2.
680539	International dial tone reset time (LOW)		
68053A	International dial tone reset time (HIGH)		
68053B	International dial tone continuous tone time		
68053C	International dial tone permissible drop time		
68053D	International dial wait interval (LOW)		
68053E	International dial wait interval (HIGH)		
68053F	Country dial tone upper frequency limit (HIGH)	Hz (BCD)	If both addresses contain FF(H), tone detection is disabled.
680540	Country dial tone upper frequency limit (LOW)		
680541	Country dial tone lower frequency limit (HIGH)		
680542	Country dial tone lower frequency limit (LOW)		
680543	Country dial tone detection time	20 ms	If 680543 contains FF, the machine pauses for the pause time (680548 / 680549).
680544	Country dial tone reset time (LOW)		
680545	Country dial tone reset time (HIGH)		
680546	Country dial tone continuous tone time		
680547	Country dial tone permissible drop time		
680548	Country dial wait interval (LOW)		
680549	Country dial wait interval (HIGH)		
68054A	Time between opening or closing the DO relay and opening the OHDI relay	1 ms	See Notes 3, 6 and 8. SP2-103-012 (parameter 11).
68054B	Break time for pulse dialing	1 ms	See Note 3. SP2-103-013 (parameter 12).
68054C	Make time for pulse dialing	1 ms	See Note 3. SP2-103-014 (parameter 13).
68054D	Time between final OHDI relay closure and DO relay opening or closing	1 ms	See Notes 3, 6 and 8. SP2-103-015 (parameter 14). This parameter is only valid in Europe.
68054E	Minimum pause between dialed digits (pulse dial mode)	20 ms	See Note 3 and 8. SP2-103-016 (parameter 15).
68054F	Time waited when a pause is entered at the operation panel		SP2-103-017 (parameter 16). See Note 3.

Address	Function	Unit	Remarks
680550	DTMF tone on time	1 ms	SP2-103-018 (parameter 17).
680551	DTMF tone off time		SP2-103-019 (parameter 18).
680552	Tone attenuation level of DTMF signals while dialing	-N x 0.5 -3.5 dBm	SP2-103-020 (parameter 19). See Note 5.
680553	Tone attenuation value difference between high frequency tone and low frequency tone in DTMF signals	-dBm x 0.5	SP2-103-021 (parameter 20). The setting must be less than -5dBm, and should not exceed the setting at 680552h above. See Note 5.
680554	PSTN: DTMF tone attenuation level after dialling	-N x 0.5 -3.5 dBm	SP2-103-022 (parameter 21). See Note 5.
680555	ISDN: DTMF tone attenuation level after dialling	-dBm x 0.5	See Note 5
680556	Not used		Do not change the settings.
680557	Time between 68054Dh (NCU parameter 14) and 68054Eh (NCU parameter 15)	1 ms	This parameter takes effect when the country code is set to France.
680558	Not used		Do not change the setting.
680559	Grounding time (ground start mode)	20 ms	The Gs relay is closed for this interval.
68055A	Break time (flash start mode)	1 ms	The OHDl relay is open for this interval.
68055B	International dial access code (High)	BCD	For a code of 100: 68055B - F1 68055C - 00
68055C	International dial access code (Low)		
68055D	PSTN access pause time	20 ms	This time is waited for each pause input after the PSTN access code. If this address contains FF[H], the pause time stored in address 68054F is used. Do not set a number more than 7 in the UK.
68055E	Progress tone detection level, and cadence detection enable flags	Bit 7 Bit 6 Bit 5 dBm 0 0 0 -25.0 0 0 1 -35.0 0 1 0 -30.0 1 0 0 -40.0 1 1 0 -49.0 Bits 2, 0 - See Note 2.	
68055F to 680564	Not used		Do not change the settings.

Address	Function	Unit	Remarks
680565	Long distance call prefix (HIGH)	BCD	For a code of 0: 680565 - FF 680566 - F0
680566	Long distance call prefix (LOW)	BCD	
680567 to 680571	Not used		Do not change the settings.
680572	Acceptable ringing signal frequency: range 1, upper limit	1000/ N (Hz).	SP2-103-003 (parameter 02).
680573	Acceptable ringing signal frequency: range 1, lower limit		SP2-103-004 (parameter 03).
680574	Acceptable ringing signal frequency: range 2, upper limit		SP2-103-005 (parameter 04).
680575	Acceptable ringing signal frequency: range 2, lower limit		SP2-103-006 (parameter 05).
680576	Number of rings until a call is detected	1	SP2-103-007 (parameter 06). The setting must not be zero.
680577	Minimum required length of the first ring	20 ms	See Note 4. SP2-103-008 (parameter 07).
680578	Minimum required length of the second and subsequent rings	20 ms	SP2-103-009 (parameter 08).
680579	Ringing signal detection reset time (LOW)	20 ms	SP2-103-010 (parameter 09).
68057A	Ringing signal detection reset time (HIGH)		SP2-103-011 (parameter 10).
68057B to 680580	Not used		Do not change the settings.
680581	Interval between dialing the last digit and switching the Oh relay over to the external telephone when dialing from the operation panel in handset mode.	20 ms	Factory setting: 500 ms
680582	<p>Bits 0 and 1 - Handset off-hook detection time</p> <p>Bit 1 0 Setting</p> <p>0 0 200 ms</p> <p>0 1 800 ms</p> <p>Other Not used</p> <p>Bits 2 and 3 - Handset on-hook detection time</p> <p>Bit 3 2 Setting</p> <p>0 0 200 ms</p> <p>0 1 800 ms</p> <p>Other Not used</p> <p>Bits 4 to 7 - Not used</p>		
680583 to 6805A0	Not used		Do not change the settings.

Address	Function	Unit	Remarks
6805A1	Acceptable CED detection frequency upper limit (high byte)	BCD (Hz)	If both addresses contain FF(H), tone detection is disabled.
6805A2	Acceptable CED detection frequency upper limit (low byte)		
6805A3	Acceptable CED detection frequency lower limit (high byte)	BCD (Hz)	If both addresses contain FF(H), tone detection is disabled.
6805A4	Acceptable CED detection frequency lower limit (low byte)		
6805A5	CED detection time	20 ms ± 20 ms	Factory setting: 200 ms
6805A6	Acceptable CNG detection frequency upper limit (high byte)	BCD (Hz)	If both addresses contain FF(H), tone detection is disabled.
6805A7	Acceptable CNG detection frequency upper limit (low byte)		
6805A8	Acceptable CNG detection frequency lower limit (high byte)	BCD (Hz)	If both addresses contain FF(H), tone detection is disabled.
6805A9	Acceptable CNG detection frequency lower limit (low byte)		
6805AA	Not used		Do not change the setting.
6805AB	CNG on time	20 ms	Factory setting: 500 ms
6805AC	CNG off time	20 ms	Factory setting: 200 ms
6805AD	Number of CNG cycles required for detection		The data is coded in the same way as address 680533.
6805AE	Not used		Do not change the settings.
6805AF	Acceptable AI short protocol tone (800Hz) detection frequency upper limit (high byte)	Hz (BCD)	If both addresses contain FF(H), tone detection is disabled.
6805B0	Acceptable AI short protocol tone (800Hz) detection frequency upper limit (low byte)		
6805B1	Acceptable AI short protocol tone (800Hz) detection frequency lower limit (high byte)	Hz(BCD)	If both addresses contain FF(H), tone detection is disabled.
6805B2	Acceptable AI short protocol tone (800Hz) detection frequency lower limit (low byte)		
6805B3	Detection time for 800 Hz AI short protocol tone	20 ms	Factory setting: 360 ms
6805B4	PSTN: Tx level from the modem	-N – 3 dBm	SP2-103-002 (parameter 01).
6805B5	PSTN: 1100 Hz tone transmission level	- N 6805B4 - 0.5N 6805B5 –3.5 (dB) See Note 7.	
6805B6	PSTN: 2100 Hz tone transmission level	- N6805B4 - 0.5N 6805B6 –3 (dB) See Note 7.	
6805B7	PABX: Tx level from the modem	- dBm	
6805B8	PABX: 1100 Hz tone transmission level	- N 6805B7 - 0.5N 6805B8 (dB)	

Address	Function	Unit	Remarks
6805B9	PABX: 2100 Hz tone transmission level	- N 6805B7 - 0.5N 6805B9 (dB)	
6805BA	ISDN: Tx level from the modem	- dBm	The setting must be between -12dBm and -15dBm.
6805BB	ISDN: 1100 Hz tone transmission level	- N 6805BA - 0.5N 6805BB (dB)	
6805BC	ISDN: 2100 Hz tone transmission level	- N 6805BA - 0.5N 6805BC (dB)	
6805BD	Modem turn-on level (incoming signal detection level)	-37-0.5N (dBm)	
6805BE to 6805C6	Not used		Do not change the settings.
6805C7	Bits 0 to 3 – Not used. Bit 4 – V.34 protocol dump 0 : Simple, 1 : Detailed (default) Bits 5 to 7 – Not used.		
6805C8 to 6805D9	Not used		Do not change the settings.
6805DA	T.30 T1 timer	1 s	
6805E0 bit 3	Maximum wait time for post message	0 : 12 s 1 : 30 s	1 : Maximum wait time for post message (EOP/EOM/MPS) can be changed to 30 s. Change this bit to “1” if communication errors occur frequently during V.17 reception.

NOTES

1. If a setting is not required, store FF in the address.
2. Italy and Belgium only

RAM address 68055E: the lower four bits have the following meaning.

Bit 2 - 1: International dial tone cadence detection enabled (Belgium)

Bit 1 - Not used

Bit 0 - 1: PSTN dial tone cadence detection enabled (Italy)

If bit 0 or bit 2 is set to 1, the functions of the following RAM addresses are changed.

680508 (if bit 0 = 1) or 680538 (if bit 2 = 1): tolerance for on or off state duration (%), and number of cycles required for detection, coded as in address 680533.

68050B (if bit 0 = 1) or 68053B (if bit 2 = 1): on time, hex code (unit = 20 ms)

68050C (if bit 0 = 1) or 68053C (if bit 2 = 1): off time, hex code (unit = 20 ms)

3. Pulse dial parameters (addresses 68054A to 68054F) are the values for 10 pps. If 20 pps is used, the machine automatically compensates.
4. The first ring may not be detected until 1 to 2.5 wavelengths after the time specified by this parameter.
5. The calculated level must be between 0 and 10.
The attenuation levels calculated from RAM data are:
High frequency tone: $-0.5 \times N_{680552/680554} - 3.5$ dBm
 $-0.5 \times N_{680555}$ dBm
Low frequency tone: $-0.5 \times (N_{680552/680554} + N_{680553}) - 3.5$ dBm
 $-0.5 \times (N_{680555} + N_{680553})$ dBm
NOTE: N_{680552} , for example, means the value stored in address 680552(H)
6. 68054A: Europe - Between Ds opening and Di opening, France - Between Ds closing and Di opening
68054D: Europe - Between Ds closing and Di closing, France - Between Ds opening and Di closing
7. Tone signals which frequency is lower than 1500Hz (e.g., 800Hz tone for AI short protocol) refer to the setting at 6805B5h. Tones which frequency is higher than 1500Hz refer to the setting at 6805B6h.
8. 68054A, 68054D, 68054E: The actual inter-digit pause (pulse dial mode) is the sum of the period specified by the RAM addresses 68054A, 68054D, and 68054E.

4.4 DEDICATED TRANSMISSION PARAMETERS

Each Quick Dial Key and Speed Dial Code has eight bytes of programmable parameters allocated to it. If transmissions to a particular machine often experience problems, store that terminal's fax number as a Quick Dial or Speed Dial, and adjust the parameters allocated to that number.

The programming procedure will be explained first. Then, the eight bytes will be described.

4.4.1 PROGRAMMING PROCEDURE

1. Set the bit 0 of System Bit Switch 00 to 1.
2. Press "Dest. Management" in the facsimile standby mode.
3. Press "Program/Change/Delete Quick Dial".
4. Select the destination key you want to program.

5. When the programmed dial number is displayed, press "Start".
Make sure that the LED of the Start button is lit as green.

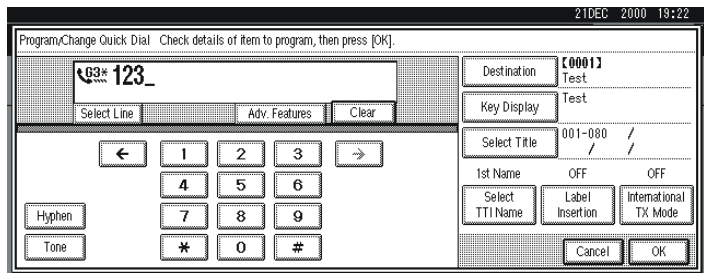

B502S104.WMF

6. The settings for the switch 01 are now displayed.
Press the bit number that you wish to change.

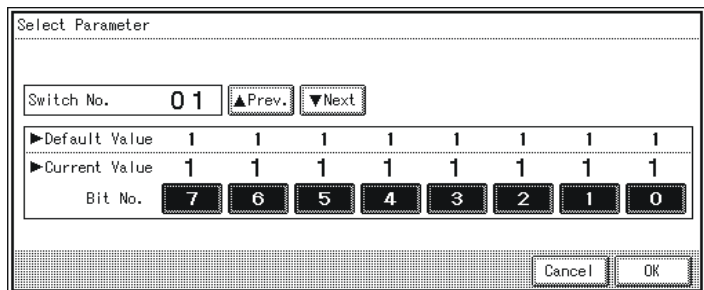

B502S105.WMF

7. To scroll through the parameter switches, either:
8. Select the next switch: press "Next"
or
Select the previous switch: "Prev." until the correct switch is displayed.
Then go back to step 6.
9. After the setting is changed, press "OK".
10. After finishing, reset bit 0 of System Bit Switch 00 to 0.

4.4.2 PARAMETERS

The initial settings of the following parameters are all FF(H) - all the parameters are disabled.

Switch 01	
FUNCTION AND COMMENTS	
ITU-T T1 time (for PSTN G3 mode) If the connection time to a particular terminal is longer than the NCU parameter setting, adjust this byte. The T1 time is the value stored in this byte (in hex code), multiplied by 1 second. Range: 0 to 120 s (00h to 78h) FFh - The local NCU parameter factory setting is used. Do not program a value between 79h and FEh.	

Switch 02		
No	FUNCTION	COMMENTS
0 to 4	Tx level Bit 4 3 2 1 0 Setting	If communication with a particular remote terminal often contains errors, the signal level may be inappropriate. Adjust the Tx level for communications with that terminal until the results are better. If the setting is "Disabled", the NCU parameter 01 setting is used. Note: Do not use settings other than listed on the left.
	0 0 0 0 0 0	
	0 0 0 0 1 -1	
	0 0 0 1 0 -2	
	0 0 0 1 1 -3	
	0 0 1 0 0 -4	
	: : 0 1 1 1 1 -15	
1 1 1 1 1 Disabled		
5 to 7	Cable equalizer Bit 7 6 5 Setting	Use a higher setting if there is signal loss at higher frequencies because of the length of wire between the modem and the telephone exchange when calling the number stored in this Quick/Speed Dial. Also, try using the cable equalizer if one or more of the following symptoms occurs. <ul style="list-style-type: none"> • Communication error with error codes such as 0-20, 0-23, etc. • Modem rate fallback occurs frequently. Note: Do not use settings other than listed on the left. If the setting is "Disabled", the bit switch setting is used.
	0 0 0 None	
	0 0 1 Low	
	0 1 0 Medium	
	0 1 1 High	
1 1 1 Disabled		

Service
Tables

Switch 03				
No	FUNCTION			COMMENTS
0 to 3	Initial Tx modem rate Bit3 2 1 0 Setting (bps)	If training with a particular remote terminal always takes too long, the initial modem rate may be too high. Reduce the initial Tx modem rate using these bits.		
	0 0 0 0	Not used		
	0 0 0 1	2,400		
	0 0 1 0	4,800		
	0 0 1 1	7,200		
	0 1 0 0	9,600		
	0 1 0 1	12,000		
	0 1 1 0	14,400		
	0 1 1 1	16,800		
	1 0 0 0	19,200		
	1 0 0 1	21,600		
	1 0 1 0	24,000		
	1 0 1 1	26,400		
	1 1 0 0	28,800		
	1 1 0 1	31,200		
	1 1 1 0	33,600		
	1 1 1 1	Disabled		
	Other settings: Not used			For the settings 14.4 or kbps slower, Switch 04 bit 4 must be changed to 0. Note: Do not use settings other than listed on the left. If the setting is "Disabled", the bit switch setting is used.
4-5	Not used			Do not change the settings.
6	AI short protocol 0: Off 1: Disabled			Refer to Appendix B in the Group 3 Facsimile Manual for details about AI Short Protocol. If the setting is "Disabled", the bit switch setting is used.
7	Not used			Do not change the settings.

Switch 04				
No	FUNCTION			COMMENTS
0 1	Inch-mm conversion before tx Bit 1 Bit 0 Setting	The machine uses inch-based resolutions for scanning. If "inch only" is selected, the printed copy may be slightly distorted at the other end if that machine uses mm-based resolutions.		
	0 0	Inch-mm conversion available		
	0 1	Inch only		
	1 0	Not used		
	1 1	Disabled		
2 to 3	DIS/NSF detection method Bit 3 Bit 2 Setting	(0, 1): Use this setting if echoes on the line are interfering with the set-up protocol at the start of transmission. The machine will then wait for the second DIS or NSF before sending DCS or NSS.		
	0 0	First DIS or NSF		
	0 1	Second DIS or NSF		
	1 0	Not used		
	1 1	Disabled		
				If the setting is "Disabled", the bit switch setting is used.

Switch 04			
No	FUNCTION		COMMENTS
4	V.8 protocol 0: Off 1: Disabled		If transmissions to a specific destination always end at a lower modem rate (14,400 bps or lower), disable V.8 protocol so as not to use V.34 protocol. 0: V.34 communication will not be possible. If the setting is "Disabled", the bit switch setting is used.
5	Compression modes available in transmit mode 0: MH only 1: Disabled		This bit determines the capabilities that are informed to the other terminal during transmission. If the setting is "Disabled", the bit switch setting is used.
6 7	ECM during transmission	Bit 7 Bit 6 Setting 0 0 Off 0 1 On 1 0 Not used 1 1 Disabled	For example, if ECM is switched on but is not wanted when sending to a particular terminal, use the (0, 0) setting. Note that V.8/V.34 protocol and JBIG compression are automatically disabled if ECM is disabled. If the setting is "Disabled", the bit switch setting is used.

Switch 05 - Not used (do not change the settings)

Switch 06 - Not used (do not change the settings)

Service
Tables

Switch 07 - Optional ISDN G4 kit required			
No	FUNCTION		COMMENTS
0 to 3	Data rate	Bits 3 2 1 0 Setting 0 0 0 0 64 kbps 0 0 0 1 56 kbps 1 1 1 1 Disabled	If the setting is "Disabled", the current setting of G4 parameter switch 2 (bits 0 and 1) is used.
4-7	Not used		Do not change the settings.

Switch 08 - Not used

Switch 09 - Optional ISDN G4 kit required			
No	FUNCTION		COMMENTS
0 to 3	Layer 3 protocol	Bits 3 2 1 0 Setting 0 0 0 0 ISO 8208 0 0 0 1 T.70 NULL 1 1 1 1 Disabled	If the setting is "Disabled", the current setting of G4 parameter switch 6 (bit 0) is used.
4 to 7	Packet modulus	Bits 3 2 1 0 Setting 0 0 0 0 Modulo 8 0 0 0 1 Modulo 128 1 1 1 1 Disabled	If the setting is "Disabled", the current setting of G4 parameter switch 6 (bit 4) is used.

Switch 10 - Optional ISDN G4 kit required		
No	FUNCTION	COMMENTS
0	Attachment of the Higher Layer Capabilities	This bit determines whether Higher Layer Capabilities are informed in the [SETUP] signal or not.
1	Not used	Do not change the setting.
2	ISDN G3 information transfer capability 0: 3.1 kHz audio 1: Speech	In tx mode, this determines the information transfer capability informed in the [SETUP] messages. In rx mode, this determines the information transfer capability that the machine can use to receive a call. Set this bit to 1 if the ISDN does not support 3.1 kHz audio.
3-7	Not used	Do not change the settings.

4.5 SERVICE RAM ADDRESSES

CAUTION

Do not change the settings which are marked as “Not used” or “Read only.”

680001 to 680004(H) - ROM version (Read only)

680001(H) - Revision number (BCD)

680002(H) - Year (BCD)

680003(H) - Month (BCD)

680004(H) - Day (BCD)

680006 to 680015(H) - Machine's serial number (16 digits - ASCII)

680018(H) - Total program checksum (low)

680019(H) - Total program checksum (high)

680020 to 68003F(H) - System bit switches

680040 to 68004F(H) - Scanner bit switches

680050 to 68005F(H) - Printer bit switches

680060 to 68007F(H) - Communication bit switches

680080 to 68008F(H) - G3 bit switches

680090 to 68009F(H) - G3-2 bit switches

6800D0(H) - User parameter switch 00 (SWUER_00) : Not used

6800D1(H) - User parameter switch 01 (SWUSR_01) : Not used

6800D2(H) - User parameter switch 02 (SWUSR_02)

Bit 0: Forwarding mark printing on forwarded messages 0: Disabled, 1: Enabled

Bit 1: Center mark printing on received copies

(This switch is not printed on the user parameter list.)

0: Disabled, 1: Enabled

Bit 2: Reception time printing

(This switch is not printed on the user parameter list.)

0: Disabled, 1: Enabled

Bit 3: TSI print on received messages 0: Disabled, 1: Enabled

Bit 4: Checkered mark printing

(This switch is not printed on the user parameter list.)

0: Disabled, 1: Enabled

Bit 5: CIL printing (G4) 0: Disabled, 1: Enabled

Bit 6: TID printing (G4) 0: Disabled, 1: Enabled

Bit 7: Not used

6800D3(H) - User parameter switch 03 (SWUSR_03: Automatic report printout)

Bit 0: Transmission result report (memory transmissions) 0: Off, 1: On

Bit 1: Not used

Bit 2: Memory storage report 0: Off, 1: On

Bit 3: Polling reserve report (polling reception) 0: Off, 1: On

Bit 4: Polling result report (polling reception) 0: Off, 1: On

Bit 5: Transmission result report (immediate transmissions) 0: Off, 1: On

Bit 6: Polling clear report 0: Off, 1: On

Bit 7: Journal 0: Off, 1: On

6800D4(H) - User parameter switch 04 (SWUSR_04: Automatic report printout)

Bit 0: Automatic confidential reception report output 0: Off, 1: On

Bits 1 to 6: Not used

Bit 7: Inclusion of a sample image on reports 0: Off, 1: On

6800D5(H) - User parameter switch 05 (SWUSR_05)

Bit 0: Substitute reception when the base copier is in an SC condition

0: Enabled, 1: Disabled

Bits 1 and 2: Condition for substitute rx when the machine cannot print messages (Paper end, toner end, jam, and during night mode)

Bit 2 1 Setting

0 0 The machine receives all the fax messages.

0 1 The machine receives the fax messages with RTI or CSI.

1 0 The machine receives the fax messages with the same ID code.

1 1 The machine does not receive anything.

Bit 3: Not used

Bit 4: Not used

Bit 5: Just size printing 0: Off, 1: On

Bit 6: Not used

Bit 7: Add paper display when a cassette is empty 0: Off, 1: On

6800D6(H) - User parameter switch 06 (SWUSR_06)

Bits 0 to 5: Not used

Bit 6: Scan sequence in Book transmission

0: Left page then right page, 1: Right page then left page

Bit 7: Not used

6800D7(H) - User parameter switch 07 (SWUSR_07)

Bits 0 and 1: Not used

Bit 2: Parallel memory transmission 0: Off, 1: On

Bits 3 to 7: Not used

6800D8(H) - User parameter switch 08 (SWUSR_08)

Bits 0 and 1: Not used.

Bit 2: Authorized reception

0: Only faxes from senders whose RTIs/CSIs are specified for this feature are accepted.

1: Only faxes from senders whose RTIs/CSIs are not specified for this feature are accepted.

Bits 3 to 7: Not used.

6800D9(H) - User parameter switch 09 (SWUSR_09) : Not used**6800DA(H) - User parameter switch 10 (SWUSR_0A)**

Bit 0: Not used

Bit 1: 2 into 1 0: Off, 1: On

Bit 2: Not used

Bit 3: Page reduction 0: Off, 1: On

Bits 4 to 7: Not used

6800DB(H) - User parameter switch 11 (SWUSR_0B)

Bit 0: Not used

Bit 1: Method of transmitting numbers after the "Tone" mark over an ISDN line
0: UUI, 1: Tone

Bits 2 to 5: Not used

Bit 6: Printout of messages received while acting as a forwarding station
0: Off, 1: On

Bit 7: Polling Standby duration 0: Once, 1: No limit

6800DC(H) - User parameter switch 12 (SWUSR_0C): Not used**6800DD(H) - User parameter switch 13 (SWUSR_0D)**

(This switch is not printed on the user parameter list.)

Bits 0 to 4: Not used

Bit 5: Action when receiving a SETUP signal containing no called number and the G4 subscriber number was programmed in this machine.

0: Respond to the call, 1: Do not respond to the call

Bit 6: Action when the received HLC (Higher Level Capabilities) is Tel or BC (Bearer Capabilities) is Speech.

0: Do not respond to the call, 1: Respond to the call

This switch determines which information transfer capabilities the machine can accept when receiving a call.

1: When the received HLC is Tel (digital telephone) or BC is Speech (voice), the machine responds to the call. In short, the machine receives every call.

This switch is useful for communication problems when the other terminal informs the above transfer capabilities although it is a fax machine.

Bit 7: ISDN SPID programming (used only in the USA)

6800DE(H) - User parameter switch 14 (SWUSR_0E)

Bit 0: Message printout while the machine is in Night Printing mode 0: On, 1: Off

Bit 1: Maximum document length detection

0: Double letter, 1: Longer than double-letter (well log) – up to 1,200 mm

Bit 2: Batch transmission 0: Off, 1: On

Bit 3: Fax mode settings, such as resolution, before a mode key (Copy/Fax/Printer/Scanner) is pressed

0: Not cleared, 1: Cleared

Bits 4 to 6: Not used

Bit 7: Manual service call (sends the system parameter list to the service station)

0: Off, 1: On

6800DF(H) - User parameter switch 15 (SWUSR_0F)

Bits 0, 1 and 2: Cassette for fax printout

Bit 2	1	0	Setting
0	0	1	1st paper feed station
0	1	0	2nd paper feed station
0	1	1	3rd paper feed station
1	0	0	4th paper feed station
1	0	1	LCT

Other settings Not used

Bits 3 and 4: Not used

Bit 5: Using the cassette specified by bits 0, 1 and 2 above only 0: On, 1: Off

Bits 6 and 7: Not used

6800E0(H) – User parameter switch 16 (SWUSR_10)

(This switch is not printed on the user parameter list.)

Bits 0 and 1: Not used

Bit 2: Paper size selection priority for an A4 size fax message when A4/LT size paper is not available.

0: A3 has priority, 1: B4 has priority

Bits 3 to 7: Not used

6800E1(H) – User parameter switch 17 (SWUSR_11)

Bits 0 and 1: Not used

Bit 2: Inclusion of the “Add” button when a sequence of Quick/Speed dials is selected for broadcasting

0:Not needed, 1: Needed

Bits 3 to 6: Not used

Bit 7: Press “Start” key without an original when using the on hook dial or the external telephone,

0: displays “Cannot detect original size”.

1: Receives fax messages.

6800E2(H) - User parameter switch 18 (SWUSR_12)

Bit 0: TTI date 0: Off, 1: On

Bit 1: TTI sender 0: Off, 1: On

Bit 2: TTI file number 0: Off, 1: On

Bit 3: TTI page number 0: Off, 1: On

Bit 4 to 7: Not used

6800E3(H) - User parameter switch 19 (SWUSR_13)

Bit 0: Offset sort function for the fax (only using the shift tray on the 1,000 sheet finisher)

0: Disabled, 1: Enabled

Bit 1: Journal format

0: The Journal is separated into transmissions and receptions

1: The Journal is separated into G3-1, G3-2, G3-3 and G4 communications

Bit 2: Action when the paper cassette that was selected by the specified cassette selection feature becomes empty.

(This switch is not printed on the user parameter list.)

0: The machine will not print any received files until paper is added.

1: The machine will use other cassettes to print received files that are not specified by this feature.

Bit 3: 90° image rotation during B5 portrait Tx

(This switch is not printed on the user parameter list.)

0: Off, 1: On

Bit 4: Reduction of sample images on reports to 50% in the main scan and sub-scan directions. (This switch is not printed on the user parameter list.)

0: Technician adjustment (printer switch 0E bits 3 and 4), 1: 50% reduction

Bit 5: Use of A5 size paper for reports

(This switch is not printed on the user parameter list.)

0: Off, 1: On

Bits 6 and 7: Not used

6800E4(H) - User parameter switch 20 (SWUSR_14)

Bit 0: Automatic printing of the PC fax (LAN fax) error report

0: Off, 1: On

Bit 1: Reprint the documents fail to print from PC fax (LAN fax) driver

0: Off, 1: On

Bits 2 to 5: Store documents in memory which could not be printed from PC fax (LAN fax) driver

Bit	5	4	3	2	Setting
	0	0	0	0	0 min.
	0	0	0	1	1 min.
			↓		↓
	1	1	1	0	14 min.
	1	1	1	1	15 min.

Bits 6 and 7: Not used.

6800E5(H) - User parameter switch 21 (SWUSR_15) : Not used

6800E6(H) - User parameter switch 22 (SWUSR_16): Not used

6800E7(H) - User Parameter switch 23 (SWUSR_17) : Not used



6800E8(H) - User parameter switch 24 (SWUSR_18)

Bits 0 and 1: File retention time (Cross reference: System switch 02 bit 4)

Bit	1	0	Setting
	0	0	File retention impossible
	0	1	24 hours
	1	0	File retention impossible
	1	1	72 hours

Bits 2 to 7: Not used

6800E9(H) - User parameter switch 25 (SWUSR_19)

Bits 0 to 3: Not used

Bit 4: RDS operation

0: Not acceptable

1: Acceptable for the limit specified by system switch 03

NOTE: This bit is only effective when RDS operation can be selected by the user (see system switch 02).

Bits 5 to 7: Not used

6800EA(H) to 6800ED(H) - User parameter switch 26 to 29 (SWUSR_1A to 1D)
: Not used

680EE(H) - User parameter switch 30 (SWUSR_1E)

Bits 0 to 6: Not used

Bit7: On hook dialing

0: PSTN, 1: ISDN

NOTE: If this bit set to 1, the on hook dialing is available on the ISDN line. But, the machine cannot use the G3 standard analog line for detecting the ringing and on hook dialing.

6800F0 to 6800FF(H) - G4 Parameter Switches

680100 to 68011F(H) - G4 Internal Switches

680160 to 68016E(H) - Service station's fax number (SP3-101)

See 68030C(H) for the type of network used for this number.

68016F to 68017D(H) - Own fax PABX extension number

68017E to 68018C(H) - Own fax number (PSTN)

68018D to 68019B(H) - Own fax number (ISDN G4)

68019C to 6801AA(H) - The first subscriber number (ISDN G3)

6801AB to 6801B9(H) - The second subscriber number (ISDN G3)

6801BA to 6801C8(H) - The first subscriber number (ISDN G4)

6801C9 to 6801D7(H) - The second subscriber number (ISDN G4)

6801D8 to 6801EB(H) - PSTN-1 RTI (Max. 20 characters - ASCII) - See the following note.

680217 to 680256(H) - TTI 1 (Max. 64 characters - ASCII) - See the following note.

680257 to 680296(H) - TTI 2 (Max. 64 characters - ASCII) - See the following note.

680297 to 6802AA(H) - PSTN-1 CSI (Max. 20 characters - ASCII)

6802AB to 6802BE(H) - PSTN-2 CSI (Max.20 characters - ASCII)

6802D3(H) - Number of PSTN-1 CSI characters (Hex)

6802D4(H) - Number of PSTN-2 CSI characters (Hex)

NOTE: If the number of characters is less than the maximum (20 for RTI, 64 for TTI), add a stop code (FF[H]) after the last character.

6802E0 to 6802E2(H) - PSTN-1 line settings

6802E0

Bits 0 and 1: PSTN access method from behind a PABX.

Bit	1	0	Setting
	0	0	Loop start
	0	1	Ground start
	1	0	Flash start
	1	1	Not used

Bit 2: Telephone line type.

0: PSTN, 1: PABX

Bits 3 and 4: Dialing type.

Bit	4	3	Setting
	0	0	Pulse dialing
	0	1	Not used
	1	0	Tone dialing
	1	1	Not used

Bits 4 to 7: Not used

6802E1: PSTN access number for loop start

Access number Hex value to program (BCD)

0	F0
↓	↓
9	F9
00	00
↓	↓
99	99

6802E2

Bit 0: Transmission disabled

0: Tx and Rx, 1: Rx only

Bit 1: Memory Lock reception

0: Enabled, 1: Disabled

Bits 2 to 7: Not used

6802E8 to 6802EA(H) - PSTN-2 line settings

6802F8 to 6802EA(H) - ISDN line settings

680300(H) - ID code (low - Hex)

680301(H) - ID code (high - Hex)

680302(H) - Confidential ID (low - BCD)

680303(H) - Confidential ID (high - BCD)

680304(H) - Memory Lock ID (low - BCD)

680305(H) - Memory Lock ID (high - BCD)

68030C(H) - Network type used for the service station number

- 0 1 (H) - PSTN-1
- 0 2 (H) - PSTN-2
- 1 0 (H) - G4
- 0 7 (H) - G3 auto selection

680310 to 680317(H) - Last power off time (Read only)

- 680310(H) - 01(H) - 24-hour clock, 00(H) - 12-hour clock (AM),
02(H) - 12-hour clock (PM)
- 680311(H) - Year (BCD)
- 680312(H) - Month (BCD)
- 680313(H) - Day (BCD)
- 680314(H) - Hour
- 680315(H) - Minute
- 680316(H) - Second
- 680317(H) - 00: Monday, 01: Tuesday, 02: Wednesday, , 06: Sunday

680324(H) - Optional equipment (Read only – Do not change the settings)

- Bit 0 to 3: Not used
- Bit 4: Function Upgrade unit 0: Not installed, 1: Installed
- Bit 5 to 7: Not used

680325(H) - Optional equipment (Read only – Do not change the settings)

- Bit 0: Function Upgrade unit 0: Not installed, 1: Installed
- Bit 1 to 3: Not used
- Bit 4: G3-2 0: Not installed, 1: Installed
- Bit 5: Not used
- Bit 6: ISDN unit 0: Not installed, 1: Installed
- Bit 7: Not used

680358 to 68036F(H) - G4 terminal ID (ASCII - Max. 24 characters)**680370 to 680383(H)** - ISDN CSI**680384(H)** - Number of ISDN CSI characters (Hex)**680389 to 68038C(H)** - ISDN G3 sub-address**68038D to 680390(H)** - ISDN G4 sub-address**680391 to 680395(H)** - SiG4 board ROM information (Read only)

- 680391(H) - Suffix
- 680392(H) - Version (BCD)
- 680393(H) - Year (BCD)
- 680394(H) - Month (BCD)
- 680395(H) - Day (BCD)

680396 to 68039A – Option G3 board (G3-2) ROM information (Read only)

- 680396(H) - Suffix (BCD)
- 680397(H) - Version (BCD)
- 680398(H) - Year (BCD)
- 680399(H) - Month (BCD)
- 68039A(H) - Day (BCD)

6803A2(H) - Option G3 board (G3-2) modem ROM version (Read only)

6803A6 to 6803AB(H) - Modem ROM version (Read only)

- 6803A6(H) - Part number (low)
- 6803A7(H) - Part number (high)
- 6803A8(H) - Control (low)
- 6803A9(H) - Control (high)
- 6803AA(H) - DSP (low)
- 6803AB(H) - DSP (high)

680406(H) - Time for economy transmission (hour in 24h clock format - BCD)

680407(H) - Time for economy transmission (minute - BCD)

680422(H) - Transmission monitor volume 00 - 07(H)

680423(H) - Reception monitor volume 00 - 07(H)

680424(H) - On-hook monitor volume 00 - 07(H)

680425(H) - Dialing monitor volume 00 - 07(H)

680426(H) - Buzzer volume 00 - 07(H)



5. DETAILED SECTION DESCRIPTIONS

5.1 OVERVIEW

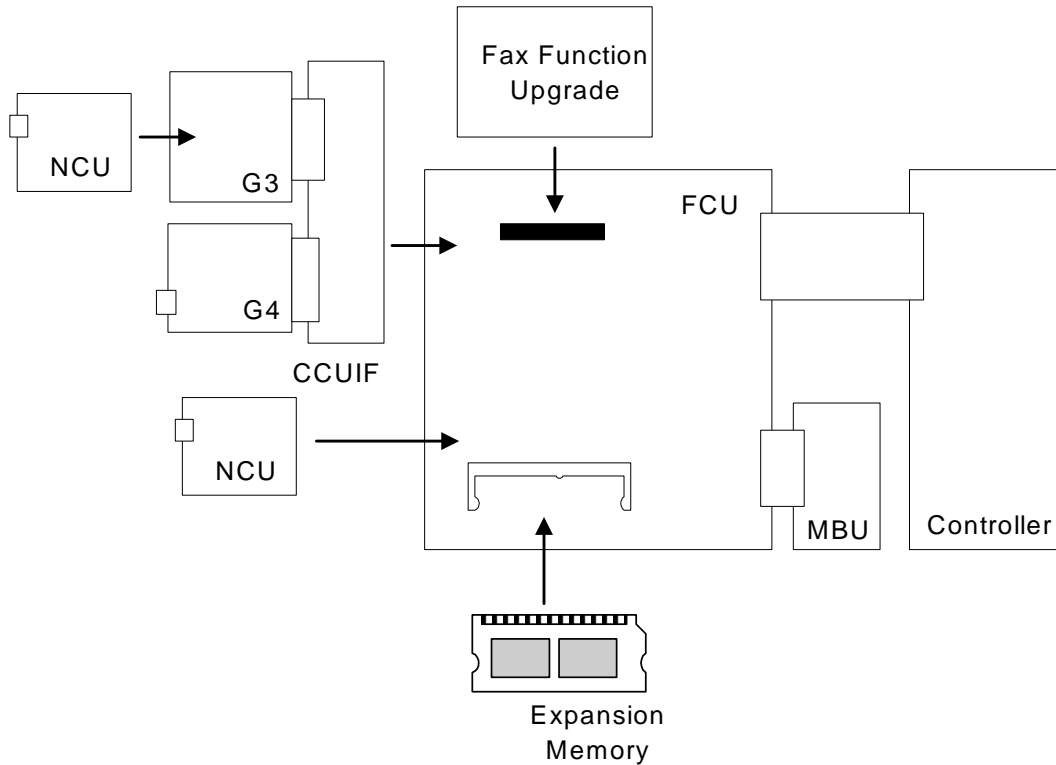

B502D501.WMF

 Detailed
Descriptions

The basic fax unit consists of two PCBs: an FCU, an MBU and an NCU.

The FCU controls all the fax communications and fax features, in cooperation with the controller board. The MBU contains the ROM and SRAM. The NCU switches the analog line between the fax unit and the external telephone.

Fax Options:

1. Extra G3 Interface option: This provides one more analog line interface. This allows full dual access. Only one extra G3 interface option can be installed. The optional G3 unit consists of two PCBs: G3 board and NCU.
2. ISDN unit: This allows the fax unit to communicate over an ISDN line.
3. Fax Function Upgrade Unit: JBIG compression becomes available. In addition, this expands the system's SRAM capacity to hold programmed telephone numbers, memory files, etc.
4. Memory Expansion: This expands the SAF memory and the page memory (used for image rotation); without this expansion, the page memory is not big enough for image rotation at 400 dpi, so transmission at 400 dpi is not possible.

5.2 BOARDS

5.2.1 FCU

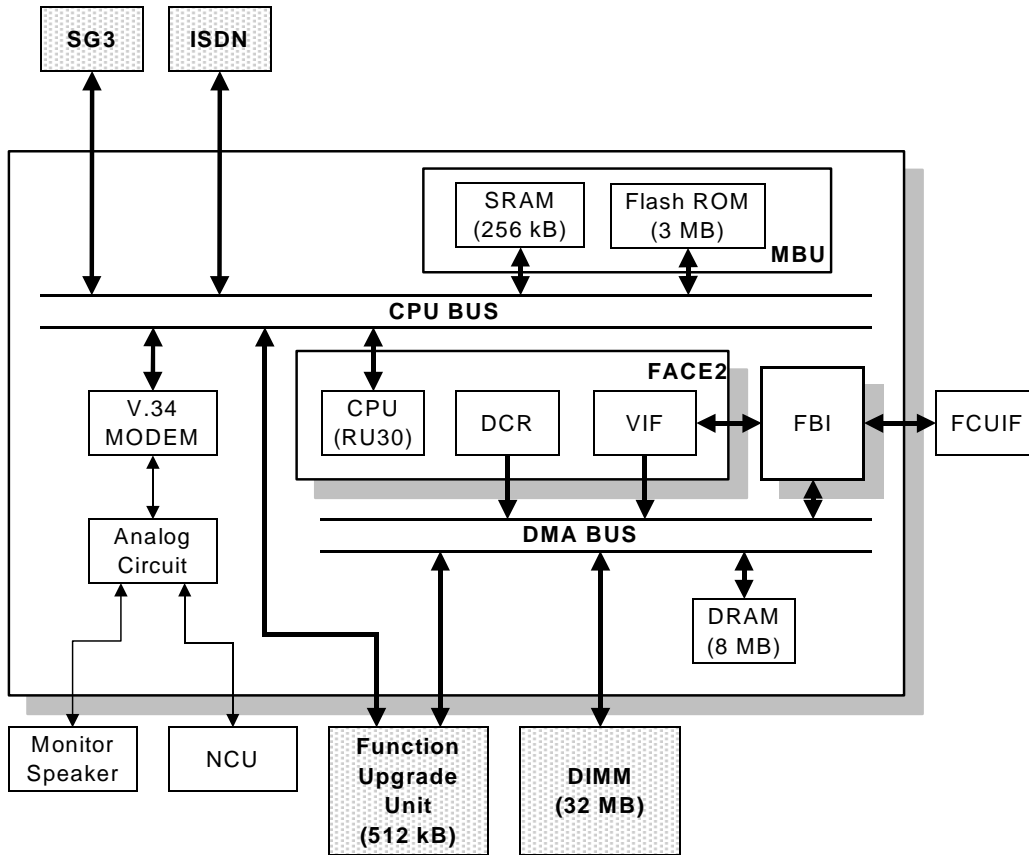

B502D510.WMF

The FCU (Facsimile Control Unit) controls fax communications, the video interface to the base copier's engine, and all the fax options.

FACE2 (Fax Application Control Engine)

- CPU
- Data compression and reconstruction (DCR)
- DMA control
- Clock generation
- DRAM backup control
- Ringing signal/tone detection

FBI (FACE Bridge Interface)

- Interface between the PCI bus and the FACE
- DMA control

Modem (R288F-29)

- V.34, V33, V17, V.29, V.27ter, V.21, and V.8

DRAM

- The 8 MB of DRAM is shared as follows.
SAF memory : 2MB
Working memory : 2MB
Page memory : 4MB
- The SAF memory is backed up by a rechargeable battery.

Memory back-up

- A Rechargeable battery backs up the SAF memory (DRAM) for 1 hour.

Switches

Item	Description
SW1	Reset switch, to reboot the FCU board

5.2.2 MBU

On this board, the flash ROM contains the FCU firmware, and the SRAM contains the system data and user parameters. Even if the FCU is changed, the system data and user parameters are kept on the MBU board.

ROM

- 3MB flash ROMs for system software storage
2MB (16bit x 1MB) + 1MB (16bit x 512K)

SRAM

- The 256 KB SRAM for system and user parameter storage is backed up by a lithium battery.

Memory back-up

- A lithium battery backs up the system parameters and programmed items in the SRAM, in case the base copier's main switch is turned off.

Switches

Item	Description
SW1	Switches the SRAM backup battery on/off.

5.2.3 NCU (US)

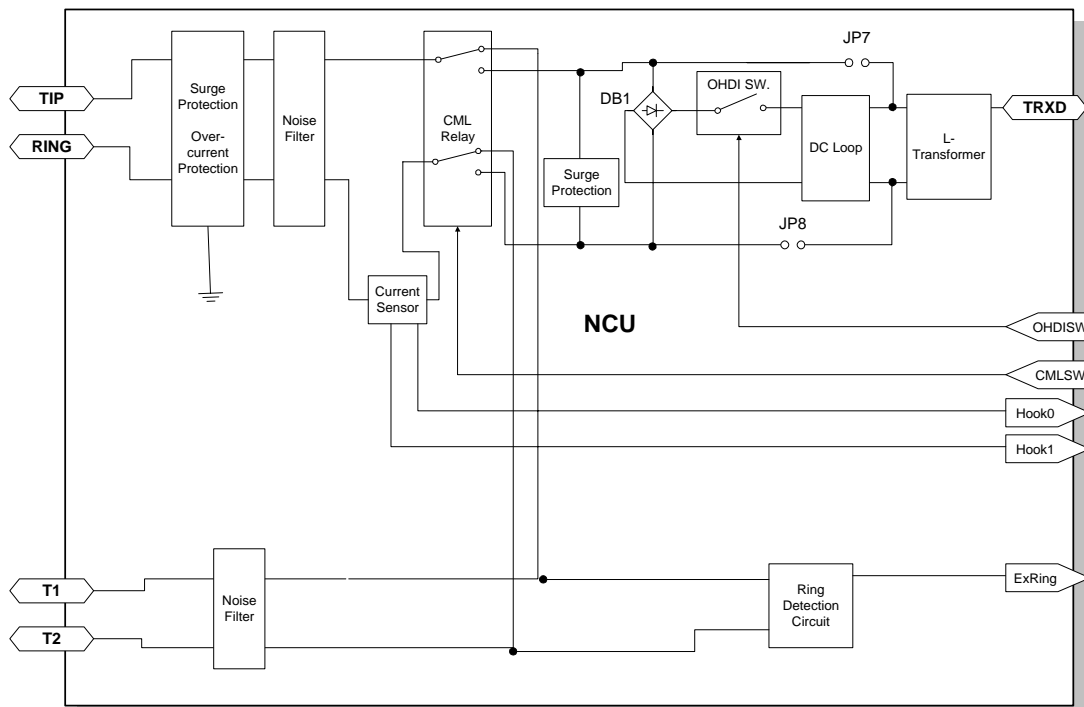

B502D520.WMF

Jumpers

Item	Description
JP7	These jumpers should be shorted when the machine is connected to a dry line.
JP8	
DB1	Also remove DB1 when the machine is connected to a dry line.

5.2.4 NCU (EUROPE/ASIA)

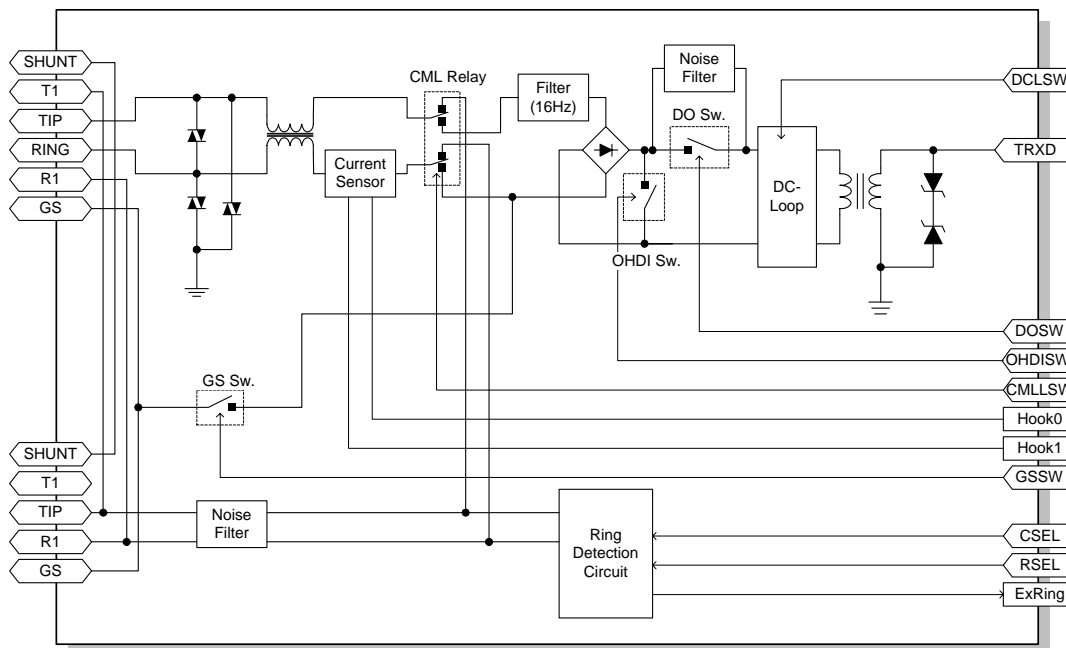

B502D521.WMF

Control Signals and Jumpers

	CSEL1	RSEL
Country	CN2-5	CN1-13
CTR21	H	H
Australia	H	H
South Africa	H	H
Malaysia	H	H
Hong Kong	L	L
New Zealand	L	L
Singapore	L	L
Asia	L	L
	L: Low, H: High	

CTR21 (Common Technical Regulation 21):

France, Germany, UK, Italy, Austria, Belgium, Denmark, Finland, Ireland, Norway, Sweden, Switzerland, Portugal, Holland, Spain, Israel, Greece

Detailed Descriptions

5.2.5 NCU (OPTIONAL G3 INTERFACE: EUROPE/ASIA)

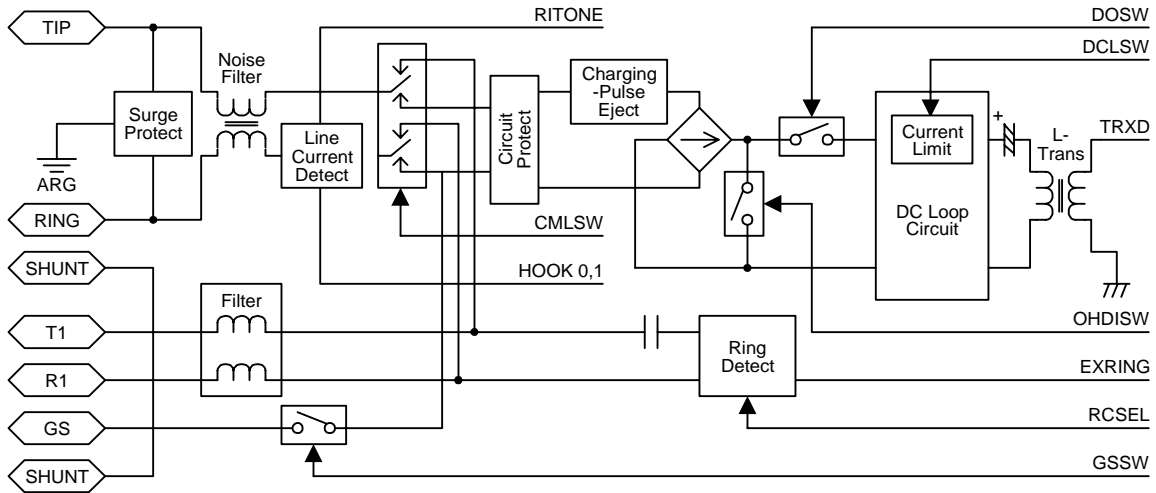

B502D901.WMF

Region/Country	TB1 [A]	TB2 [B]
Hong Kong	OFF	OFF
Hungary	ON	ON
Poland	ON	ON
Czech Republic	ON	ON
Israel	ON	ON
South Africa	ON	ON
Regions/countries where the CTR21 standard is valid	ON	ON
Other	ON	OFF

TB1 ON: Keep the jumper attached. **OFF:** Remove the jumper.
TB2 ON: Keep the jumper at ON. **OFF:** Move the jumper to OFF.

5.2.6 SG3 BOARD

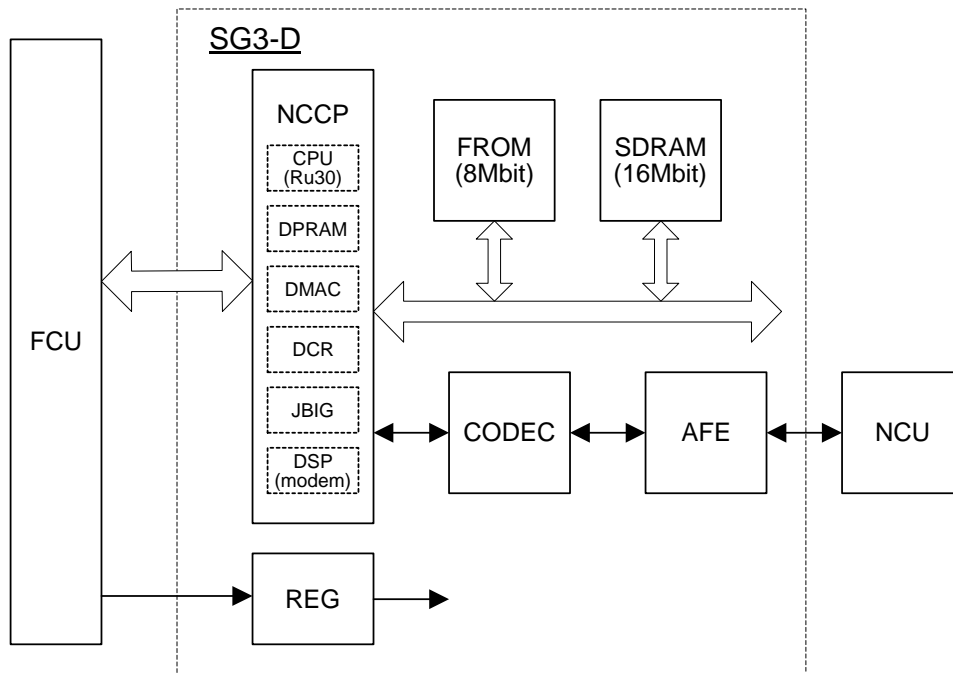

B502D902.WMF

The SG3 board allows up to two simultaneous communications when used in combination with the FCU.

NCCP (New Communication Control Processor)

- Controls the SG3 board.
- CPU (RU30)
- DPRAM (Dual Port RAM): Handshaking with the FCU is done through this block.
- DMA controller
- JBIG
- DSP V34 modem (RL5T892): Includes the DTMF Receiver function
- DCR for MH, MR, MMR, and JBIG compression and decompression

FROM

- 8M flash ROM for SG3 software storage and modem software storage

SDRAM

- 16M DRAM shared between ECM buffer, line buffer, and working memory

AFE (Analog Front End)

- Analog processing

CODEC (COder-DECoder)

- A/D & D/A conversions for modem

REG

- Generates +3.3 V from the +5V from the FCU

5.2.7 SIG4 BOARD

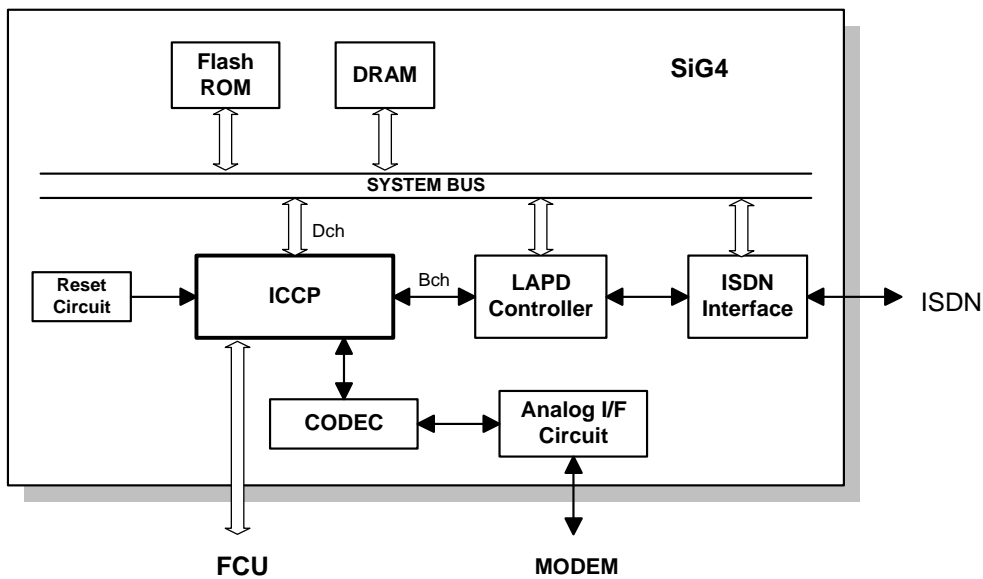

B502D500.WMF

The SiG4 (Standard ISDN G4) board contains ICCP (ISDN Communication Control Processor), Flash ROM, DRAM, LAPD controller, CODEC, ISDN interface and analog interface. The ICCP controls the entire board.

ICCP (ISDN Communication Control Processor)

- 16 bit CPU which controls the entire board
- HDLC control
- Channel select for B channel interface control

CODEC

- A/D, D/A converter for ISDN G3 communication

LAPD Controller

- ISDN layer 1 and LAPD control

ROM

- 512 kB (4 Mbit) Flash ROM for system software storage

DRAM

- 2MB (16 Mbit) DRAM used

5.3 VIDEO DATA PATH

5.3.1 TRANSMISSION

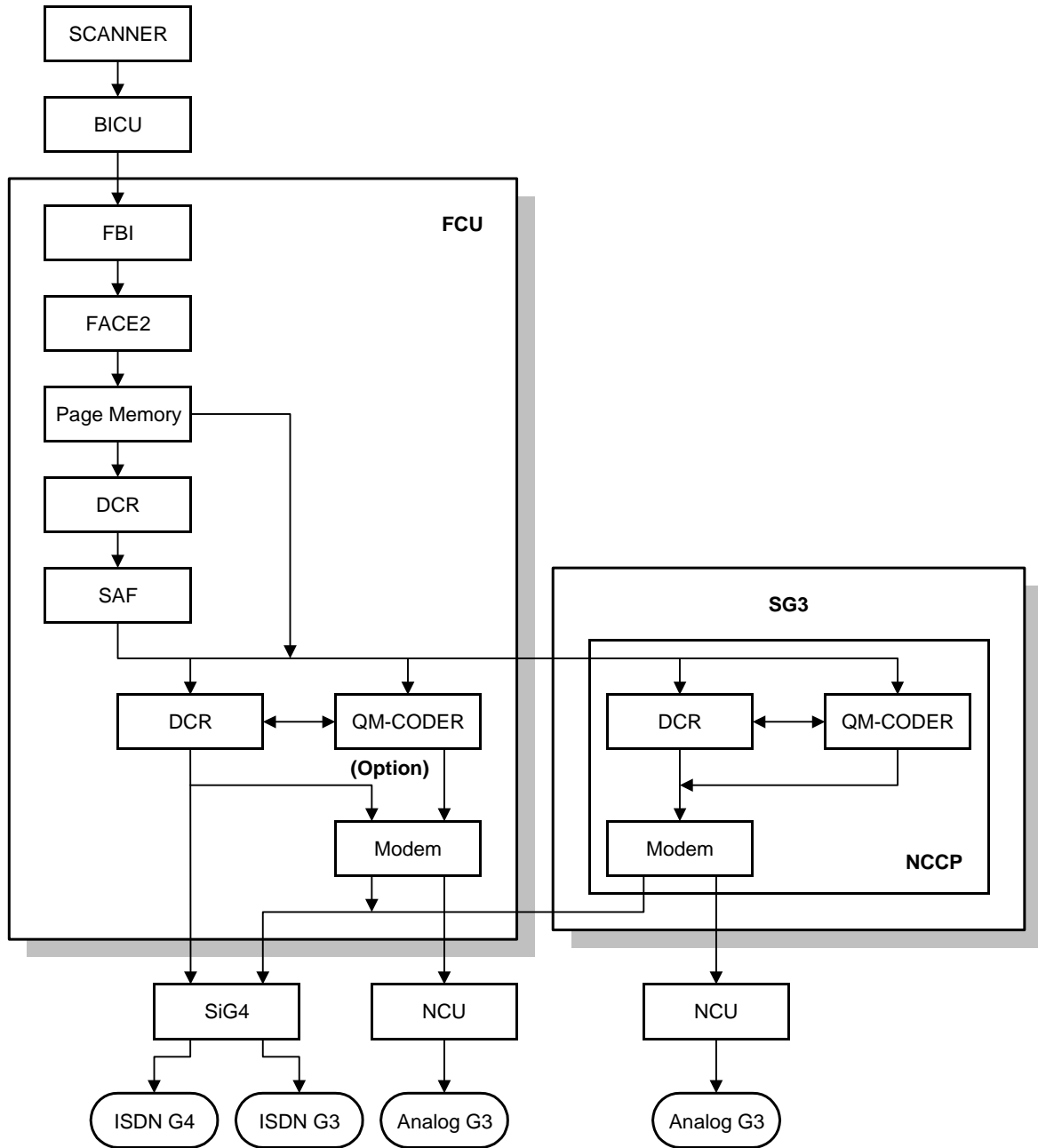

Detailed Descriptions

Memory Transmission and Parallel Memory Transmission

The base copier's scanner scans the original at the selected resolution in inch format. The BICU processes the data and transfers it to the FCU.

NOTE: When scanning a fax original, the BICU uses the MTF, independent dot erase and thresholding parameter settings programmed in the fax unit's scanner bit switches, not the copier's SP modes.

Then, the FCU converts the data to mm format, and compresses the data in MMR or raw format to store it in the SAF memory. If image rotation will be done, the image is rotated in page memory before compression.

At the time of transmission, the FCU decompresses the stored data, then re-compresses and/or reduces the data if necessary for transmission. Either the NCU or SiG4 (optional) transmits the data to the line.

Immediate Transmission

The base copier's scanner scans the original at the resolution agreed with the receiving terminal. The BICU video processes the data and transfers it to the FCU.

NOTE: When scanning a fax original, the BICU uses the MTF, independent dot erase and thresholding parameter settings programmed in the fax unit's scanner bit switches, not the copier's SP modes.

Then the FCU stores the data in page memory, and compresses the data for transmission. Either the NCU or SiG4 (optional) transmits the data to the line.

JBIG Transmission

- **Memory transmission:** If the receiver has JBIG compression, the data goes from the DCR to the QM-Coder on the Function Upgrade Unit for JBIG compression. Then either the NCU or SiG4 (ISDN G3) transmits the data to the line. When an optional G3 unit (SG3) is installed and PSTN2 is selected as the line type, JBIG compression is available, but only for the PSTN-2 line.
- **Immediate transmission:** If the receiver has JBIG compression, the data goes from the page memory to the QM-Coder on the Function Upgrade Unit for JBIG compression. Then either the NCU or SiG4 (ISDN G3) transmits the data to the line. When an optional G3 unit (SG3) is installed and PSTN2 is selected as the line type, JBIG compression is available, but only for the PSTN-2 line.

I-G3 (ISDN G3) Transmission

G3 transmission is available through the ISDN line by using the optional G4 unit (SiG4). In this case, the G3 modem is used for the I-G3 transmission. When an optional G3 unit (SG3) is installed, the modem on the SG3 can be also used for the I-G3 transmission. This means that two I-G3 transmission is available at the same time.

Adjustments

- Line used for G3 transmissions (PSTN or ISDN): System switch 0A bit 6
- Line used for G3 transmissions (PSTN 1/PSTN 2): System switch 16 bit 1
- I-G3 modem default: System switch 16 bit 2 and 3

5.3.2 RECEPTION

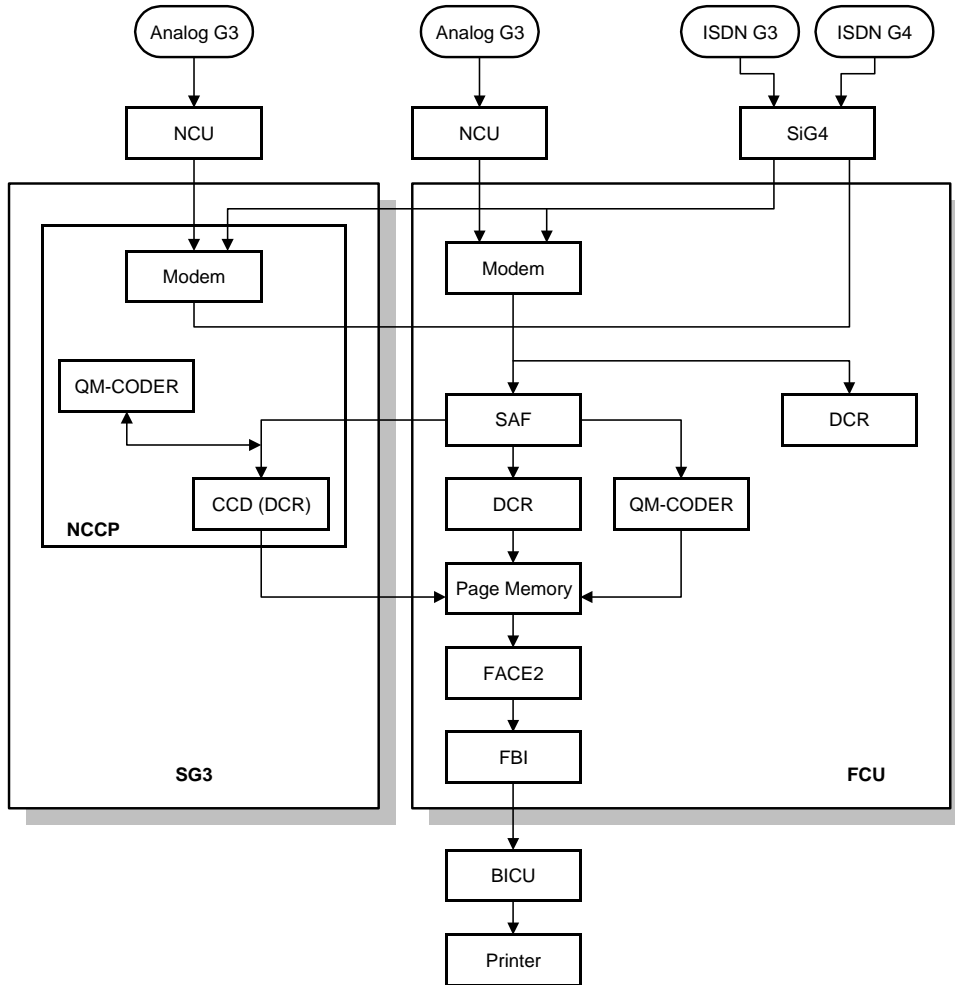

B502D512.WMF

Detailed Descriptions

First, the FCU stores the incoming data from either an analog line or an ISDN line to the SAF memory. (The data goes to the FACE at the same time, and is checked for error lines/frames.)

The FCU then decompresses the data and transfers it to page memory. If image rotation will be done, the image is rotated in the page memory. The data is transferred to the BICU.

If the optional G3 unit is installed, the line that the message comes in on depends on the telephone number dialed by the other party (the optional G3 unit has a different telephone number from the main fax board).

JBIG Reception

When data compressed with JBIG comes in on PSTN-1 (the standard analog line), the data is sent to the Function Upgrade Unit for decompression. Then the data is stored in the page memory, and transferred to the IPU.

When data compressed with JBIG comes in on PSTN-2 (optional extra analog line), the data is sent to the QM-CODER on the SG3 board for decompression.

5.4 FAX COMMUNICATION FEATURES

5.4.1 PERSONAL/INFORMATION/TRANSFER BOXES

When an incoming message has a SUB or SEP code attached, the machine will look for a Personal Box, Transfer Box or Information Box with an identical SUB or SEP code. If a matching code is found, the message will be stored in the box and not printed, or it will be forwarded to the receiver if registered.

Personal Box (Confidential Box)

The user can create personal boxes in the machine's memory for receiving fax messages. Each box must have a name and a code.

If a sender knows the code that was used to create a personal box, they can specify this as the SUB code during transmission. The message will then go to this personal box. If the sender also sends a SID code, this is ignored; the receiver must input the SID code stored in the receiving machine to print the message (the receiver's SID code acts as a password).

The receiver can set up the personal box as a forwarding station – any messages entering the box will be forwarded to another station.

Items to program at the receiving machine

Items	Note
SUB Code (Box number)	Required
Box name	Required
Password (SID)	Optional
Receiver (1 forwarding destination)	Optional (Quick Dial)

Items for the sender to specify when setting up the transmission

Items	Note
SUB Code (Box number)	Required (must be the same as the code that was used to set up the personal box)
Password (SID)	Optional

- NOTE:**
- 1) Group dial is not available for the forwarding destination
 - 2) If the sender uses a SID code, this code is ignored. The communication can proceed even if the SID code stored in the machine is different. In addition, the SID code stored in the machine must be used to print the stored message, and not the SID code from the sender.
 - 3) If a forwarding destination is programmed, the received file is deleted after delivering the documents to the pre-programmed receiver. If forwarding did not succeed, the forwarding result report is printed out but the file stays in the memory until it is printed out on the machine.

Transfer Box

The user can create transfer boxes in the machine’s memory for forwarding incoming fax messages. Each box must have a name and a code. Each box must also have destinations associated with it; any message arriving in this box will automatically be sent on to these destinations.

If a sender knows the code that was used to create a transfer box, they can specify this as the SUB code during transmission. The message will then go to this transfer box, and will be sent on to the transfer destinations associated with that transfer box.

If the sender also sends a SID code, the SID code stored in the receiver must be the same or the communication will be disconnected.

Items to program at the receiving machine

Items	Note
SUB Code (Box number)	Required
Box name	Required
Password (SID)	Optional
Receiver (Final destinations)	Required (Quick Dial)

Items for the sender to specify when setting up the transmission

Items	Note
SUB Code (Box number)	Required (must be the same as the code that was used to set up the transfer box)
Password (SID)	Optional

Detailed Descriptions

- NOTE:**
- 1) 5 destinations can be programmed with Group or Quick Dial as the delivery destinations.
 - 2) More than 5 destinations are available if a Group is specified as one of the destinations.
 - 3) If the SID does not match, the communication is disconnected.
 - 4) A result report is not sent back to the transmitter but it is printed on the receiving machine.

Information Box (Polling Tx)

The user can set up documents in memory to be picked up by another machine. The user makes an information box for each document.

The information box is identified by a code. Anybody who wishes to call the fax machine and receive the document from the information box has to input this code as the SEP code when calling the machine.

In addition, the user who sets up the information box can protect it with a password. This protects the document from other people at the same location (to print the stored document, this password must be input). The person who wishes to receive the document does not have to know this PWD code, but only has to know the SEP code.

Items to program at the machine that has the document on standby for polling

Items	Note
SEP Code (Box number)	Required
Box name	Required
Password (PWD) for printing the stored document	Optional

Items for the caller to specify when picking up the document

Items	Note
SEP Code (Box number)	Required (must be the same as the code that was used to set up the information box)

- NOTE:** 1) Only one fax message can go in each information box.
 2) The SEP code must be different for each box.

5.4.2 MULTI-PORT

When the optional ISDN Unit or optional extra G3 Interface Unit is installed, communication can take place at the same time through the two or three lines at once.

Option	Available Line Type	Available protocol Combinations
Standard only	PSTN	G3
Extra G3 Interface Unit	PSTN + PSTN	G3 + G3
ISDN Unit	PSTN + ISDN	G3 + G4
	ISDN	I-G3 + G4
Extra G3 Interface Unit + ISDN Unit	PSTN + PSTN + ISDN	G3 + G3 +G4
	PSTN + ISDN	G3 + I-G3 or G3 + I-G3 + G4
	ISDN	I-G3 + I-G3 or I-G3 + G4

5.4.3 DOCUMENT SERVER

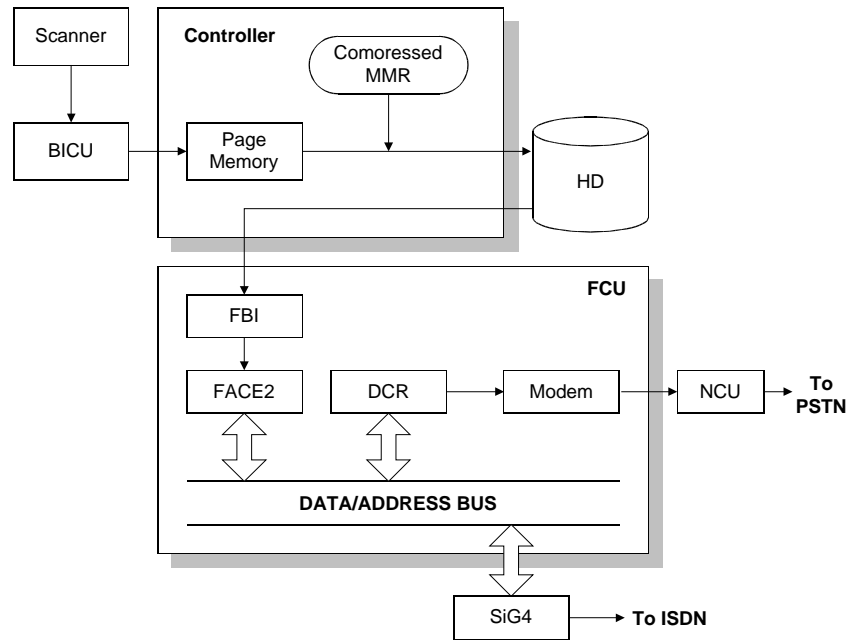

B502D514.WMF

The base copier's scanner scans the original at the selected resolution. The BICU video processes the data and transfers it to the controller board.

Then the controller stores the data in the page memory for the copier function, and compresses the data in MMR (by software) to store it in the HDD. If image rotation will be done, the image is rotated in the page memory before compression.

For transmission, the stored image data is transferred to the FCU. The FCU decompresses the image data, then recompresses and/or reduces the data if necessary for transmission. Either the NCU or SiG4 (optional) transmits the data to the line.

The documents can be stored in the HDD (Document Server) from the fax application. The stored documents in the document sever can be used for the fax transmission in many times. More than one document and the scanned document can be combined into one file and then the file can be transmitted.

- When using the document server, the SAF memory is not used.
- The document is compressed with MMR and stored.
- Up to 9,000 pages can be stored. (1 file: Up to 1,000 pages with Fax Function Upgrade and Expansion Memory) from the fax application.
- Only stored documents from the fax application can be transmitted.
- Scanned documents are given a name automatically, such as "FAX001". But it is possible to change the file name, user name and password.
- Up to 30 files can be selected at once.

NOTE: 1) The compression method of the fax application is different from the copy application. The storing time is longer than the copier storing.
 2) When selecting "Print 1st page", the stored document will be reduced to A4 size.

5.4.4 LAN FAX DRIVER

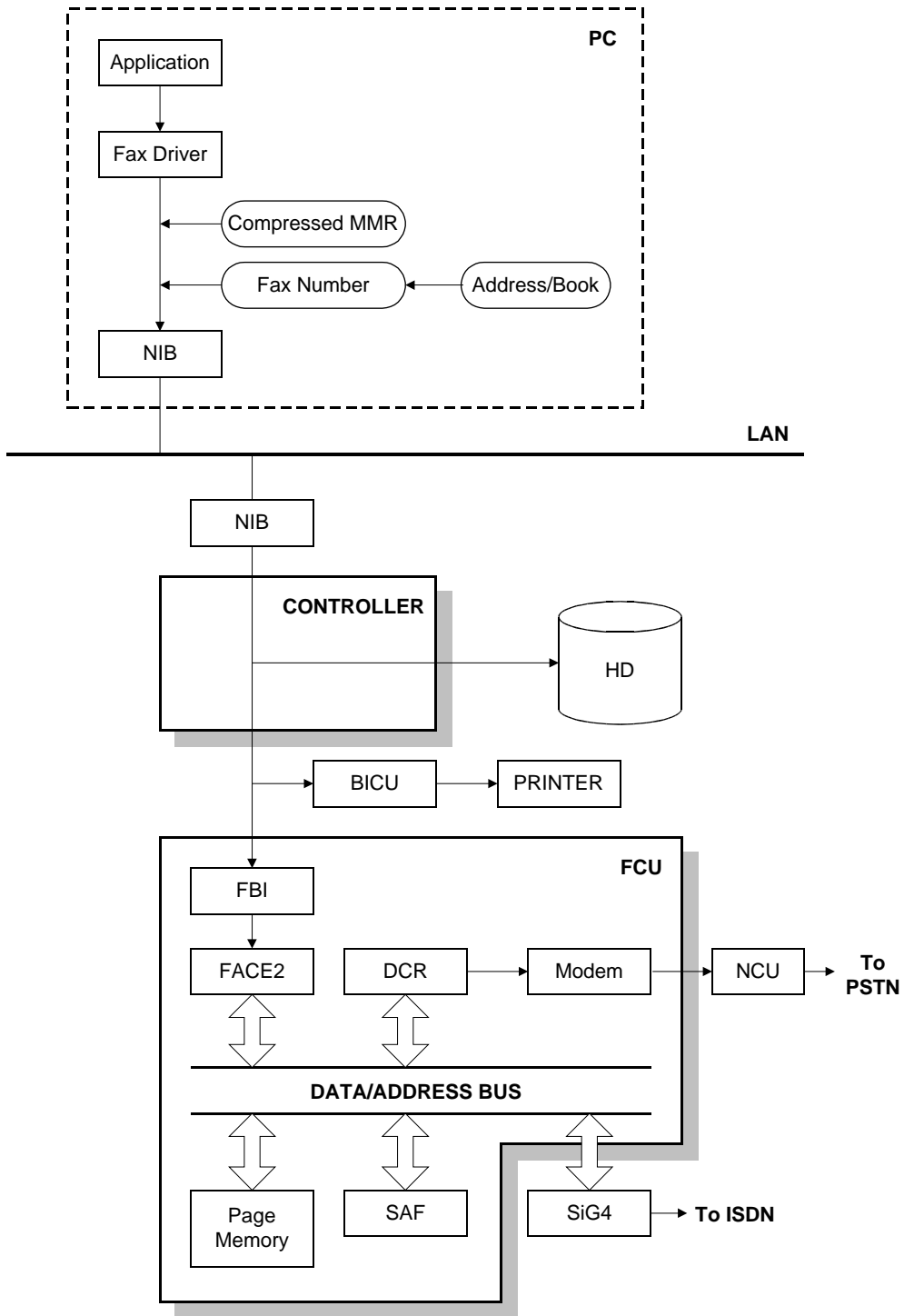

Detailed Descriptions

The fax driver makes print data from an application, then compresses the print data into MMR data. PjL commands are added to the compressed data and the destination telephone number and the line selection are included in the PjL commands. The telephone number can be taken from an address book application.

The fax driver uses TCP/IP protocol to transfer the print (MMR) data to the machine.

Regular Transmission

The machine stores the print (MMR) data in the SAF memory. Then, the print data is transferred using the same method as memory transfer.

Print and Transmission

The machine stores the print (MMR) data in the page memory on the controller. Then, the machine decompresses the print data and prints out. The decompressed print data is transferred to the FCU and is stored to page memory.

Even if the Expansion Memory is not installed, it is possible to transmit and print the document from the PC with 400 dpi resolution. However, the data is converted to 200 dpi and printed out if the data stored in the SAF memory for memory transmission. This is because the page memory on the FCU is not enough to expand the print data to 400 dpi with only standard memory.

Using the Document Server

At first, the machine stores the print (MMR) data in the HDD, when using the Document Server. Then the print data is transferred to the FCU. But the FCU does not store this data in the SAF memory. Then the print data is transferred using the same method as Document Server transmission.

SPECIFICATIONS

1. GENERAL SPECIFICATIONS

Type:	Desktop type transceiver
Circuit:	PSTN (max. 2ch.) PABX ISDN
Connection:	Direct couple
Original Size:	Book (Face down) Maximum Length: 432 mm [17 ins] Maximum Width: 297 mm [11.7 ins] ARDF (Face up) (Single-sided document) Length: 128 - 1200 mm [5.0 - 47.2 ins] Width: 105 - 297 mm [4.1 - 11.7 inch] (Double-sided document) Length: 128 - 432 mm [5.0 - 17 inch] Width: 105 - 297 mm [4.1 - 11.7 inch]
Scanning Method:	Flat bed, with CCD
Resolution:	G3 8 x 3.85 lines/mm (Standard) 8 x 7.7 lines/mm (Detail) 8 x 15.4 line/mm (Fine) Note1 16 x15.4 line/mm (Super Fine) See Note 1 200 x 100 dpi (Standard) 200 x 200 dpi (Detail) 400 x 400 dpi (Super Fine) See Note 1 G4 200 x 100 dpi (Standard) 200 x 200 dpi (Detail) 400 x 400 dpi (Super Fine) See Note 1 NOTE: 1. Optional Expansion Memory required
Transmission Time:	G3: 3 s at 28800 bps; Measured with G3 ECM using memory for an ITU-T #1 test document (Slerexe letter) at standard resolution G4: 3 s at 64 kbps; Measured with an ITU-T #1 test document (Slerexe letter) at standard resolution
Data Compression:	MH, MR, MMR JBIG (optional Fax Function Upgrade Unit required)
Protocol:	Group 3 with ECM Group 4 (ISDN unit required)

SPECIFICATIONS

26 July 2002

Modulation:	V.34, V.33, V.17 (TCM), V.29 (QAM), V.27ter (PHM), V.8, V.21 (FM)
Data Rate:	G3: 33600/31200/28800/26400/24000/21600/ 19200/16800/14400/12000/9600/7200/4800/2400 bps Automatic fallback G4: 64 kbps/56 kbps
I/O Rate:	With ECM: 0 ms/line Without ECM: 2.5, 5, 10, 20, or 40 ms/line
Memory Capacity:	ECM: 128 KB SAF Standard: 2 MB With optional Expansion Memory: 26 MB (2 MB+ 24 MB) Page Memory Standard: 4 MB (Print: 2 MB + Scanner: 2 MB) With optional Expansion Memory: 12 MB (4 MB + 8 MB) (Print 8 MB + Scanner: 4 MB)

2. CAPABILITIES OF PROGRAMMABLE ITEMS

The following table shows how the capabilities of each programmable item will change after the optional Fax Function Upgrade Unit is installed.

Item	Standard	With Fax Function Upgrade Unit
Quick Dial	400	1200
Groups	64	64
Destination per Group	500	500
Boxes (Information/Personal/Transfer)	150	400
Destinations dialed from the ten-key pad overall	100	1000
Programs	100	200
Auto Document	6	18
Communication records for Journal stored in the memory	200	1000
Specific Senders	30	50

The following table shows how the capabilities of the document memory will change after the optional Fax Function Upgrade Unit and the Expansion Memory are installed.

		Without the Expansion Memory	With the Expansion Memory
Memory Transmission file	Without the Fax Function Upgrade Unit	400	400
Maximum number of page for memory transmission		400	1000
Memory capacity for memory transmission (Note1)		160	1000
Memory Transmission file	With the Fax Function Upgrade Unit	800	800
Maximum number of page for memory transmission		400	3000
Memory capacity for memory transmission (Note1)		160	2080

Spec.

NOTE: Measured using an ITU-T #1 test document (Slerexe letter) at the standard resolution, the auto image density mode and the Text mode.

3. MACHINE CONFIGURATION

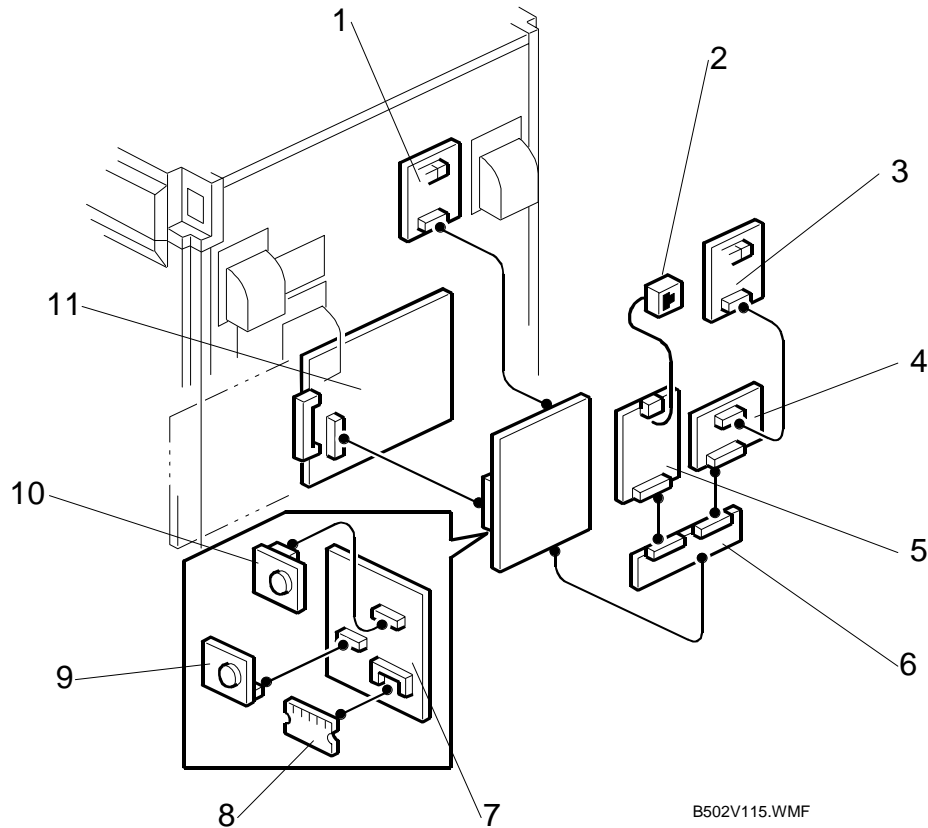

No.	Description	No.	Description	No.	Description
1	NCU board	5	SiG4 board	9	Fax function upgrade kit
2	Modular jack	6	CCU interface board	10	MBU board
3	Optional NCU board	7	FCU board	11	Controller board
4	SG3-D board	8	Expansion memory		

Item	Machine Code	No.	Remarks
Fax Option Type 1232	B502	1, 7, 10	
G3 Interface Unit Type 1232	B503	3, 4, 6	
ISDN Option Type 1232	B504	2, 5, 6,	
Fax Function Upgrade Kit 185	A892	9	<ul style="list-style-type: none"> • Used in common with Stinger-C, A-C2, and Russian-C2
Handset Type 1018	B433	—	<ul style="list-style-type: none"> • USA only • Used in common with Kir C1
Expansion Memory	—	8	<ul style="list-style-type: none"> • Not provided (procure locally) • Used in common with Stinger-C, Russian-C2, and A-C2
Marker Type 30	H903	—	<ul style="list-style-type: none"> • Refill ink for stamp